

**Model:
6000TRS-CE**

Installers Guide

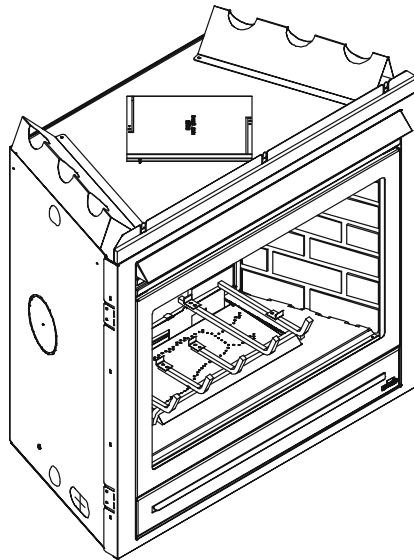

**WARNING:
IF THE INFORMATION IN THESE
INSTRUCTIONS IS NOT
FOLLOWED EXACTLY, A FIRE OR
EXPLOSION MAY RESULT
CAUSING PROPERTY DAMAGE,
PERSONAL INJURY, OR DEATH.**

- Do not store or use petrol or other flammable vapors and liquids in the vicinity of this or any other appliance.
- **What to do if you smell gas**
 - Do not try to light any appliance.
 - Do not touch any electrical switch.
 - Do not use any phone in your building.
 - Immediately call your gas supplier from a neighbor's phone. Follow the gas supplier's instructions
 - If you cannot reach your gas supplier, call the fire department.
- Installation and service must be performed by a qualified installer or competent person.

READ THIS MANUAL BEFORE INSTALLING OR OPERATING THIS APPLIANCE. THIS *INSTALLERS GUIDE* MUST BE LEFT WITH APPLIANCE FOR FUTURE REFERENCE.

WARNING: IMPROPER INSTALLATION, ADJUSTMENT, ALTERATION, SERVICE OR MAINTENANCE CAN CAUSE INJURY OR PROPERTY DAMAGE. REFER TO THIS MANUAL. FOR ASSISTANCE OR ADDITIONAL INFORMATION CONSULT A QUALIFIED INSTALLER OR COMPETENT PERSON.

These instructions are only valid if the following country symbol is on the appliance. If this symbol is not present on the appliance, it is necessary to refer to the technical instructions which will provide the necessary information concerning the modification of the appliance to the conditions of use for the country.

These instructions are valid for the following countries: GB, IE

Printed in U.S.A. Copyright 2004
Heat-N-Glo, a brand of Hearth & Home Technologies Inc.
20802 Kensington Blvd., Lakeville, MN 55044, USA

Please contact your Heat-N-Glo dealer with any questions or concerns. For the number of your nearest Heat-N-Glo dealer, please call 1-888-427-3973.

This product is covered by one or more of the following patents: (United States) 4,112,913; 4,408,594; 4,422,426; 4,424,792; 4,520,791; 4,793,322; 4,852,548; 4,875,464; 5,000,162; 5,016,609; 5,076,254 5,191,877; 5,218,953; 5,328,356; 5,429,495; 5,452,708; 5,542,407; 5,613,487; (Australia) 543790; 586383; (Canada) 1,123,296; 1,297,746; 2,195,264; (Mexico) 97-0457; (New Zealand) 200265; or other U.S. and foreign patents pending.

SAFETY AND WARNING INFORMATION



READ and **UNDERSTAND** all instructions carefully before starting the installation. **FAILURE TO FOLLOW** these installation instructions may result in a possible fire hazard and will void the warranty.



Prior to the first firing of the fireplace, **READ** the Using Your Fireplace section of the *Users Guide*.



DO NOT USE this appliance if any part has been under water. Immediately **CALL** a qualified service technician to inspect the unit and to replace any part of the control system and any gas control which has been under water.



THIS UNIT IS NOT FOR USE WITH SOLID FUEL.



Installation and repair should be **PERFORMED** by a qualified service person. The appliance and flue system should be **INSPECTED** before initial use and at least annually by a professional service person.



Always **KEEP** the appliance clear and free from combustible materials, petrol, and other flammable vapors and liquids.



NEVER OBSTRUCT the flow of combustion and ventilation air. Keep the front of the appliance **CLEAR** of all obstacles and materials for servicing and proper operations.



Due to the high temperature, the appliance should be **LOCATED** out of traffic areas and away from furniture and draperies. Clothing or flammable material **SHOULD NOT BE PLACED** on or near the appliance.



Children and adults should be **ALERTED** to the hazards of high surface temperature and should **STAY AWAY** to avoid burns or clothing ignition. Young children should be **CAREFULLY SUPERVISED** when they are in the same room as the appliance.



These units **MUST** use one of the fluing systems described in the Installing the Fireplace section of the *Installers Guide*. **NO OTHER** flue systems or components **MAY BE USED**.



This gas appliance and flue assembly **MUST** be vented directly to the outside and **MUST NEVER** be attached to a chimney serving a separate solid fuel burning appliance. Each gas appliance **MUST USE** a separate flue system. Common flue systems are **PROHIBITED**.



INSPECT the external terminal cap on a regular basis to make sure that no debris is interfering with the air flow.



The glass door assembly **MUST** be in place and sealed, and the trim door assembly **MUST** be in place on the appliance before the unit can be placed into safe operation.



DO NOT OPERATE this appliance with the glass door removed, cracked, or broken. Replacement of the glass door should be performed by a licensed or qualified service person. **DO NOT** strike or slam the glass door.



The glass door assembly **SHALL ONLY** be replaced as a complete unit, as supplied by the gas appliance manufacturer. **NO SUBSTITUTE** material may be used.



DO NOT USE abrasive cleaners on the glass door assembly. **DO NOT ATTEMPT** to clean the glass door when it is hot.



Turn off the gas before servicing this appliance. It is recommended that a qualified service technician perform an appliance check-up at the beginning of each heating season.



Any safety screen or guard removed for servicing must be replaced before operating this appliance.



This appliance is intended for use on a gas installation with a governed meter.

Safety and Warning Information	2
Service Parts List	4
Section 1: Approvals and Regulations	7
Appliance Certification	7
Installation Regulations	7
Section 2: Getting Started	8
Introducing the Heat-N-Glo Gas Fireplaces	8
Pre-installation Preparation	8
Section 3: Installing the Fireplace	10
Step 1 Locating the Fireplace	10
Step 2 Framing the Fireplace	11
Step 3 Installing the Flue System	12
A. Flue System Approvals	12
B. Installing Flue Components	20
C. Flue Termination	24
Step 4 Positioning, Leveling and Securing the Fireplace	29
Step 5 The Gas Control Systems	29
Step 6 The Gas Supply Line	30
◆ Step 7 Gas Pressure Requirements	31
Step 8 Wiring the Fireplace	31
Step 9 Finishing	32
Step 10 Installing Trim, Logs & Ember Material	33
Installing the Trim	33
Positioning the Logs	34
Placing the Ember Material	36
Step 11 Before Lighting the Fireplace	37
Step 12 Lighting the Fireplace	37
After the Installation	37
Section 4: Maintaining and Servicing Your Fireplace	38
Section 5: Troubleshooting	40

Table of Contents

◆ = Contains updated information.

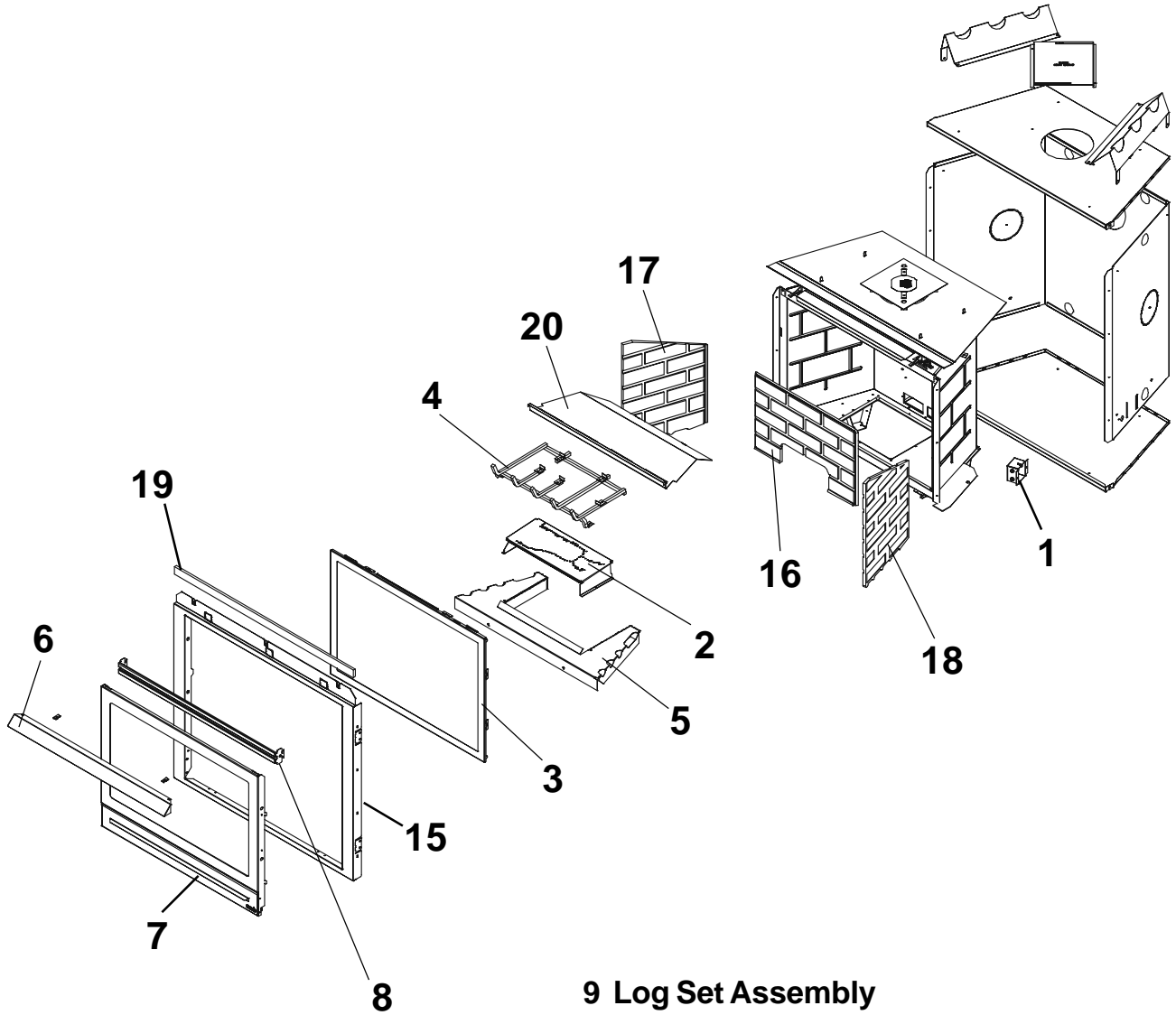

9 Log Set Assembly

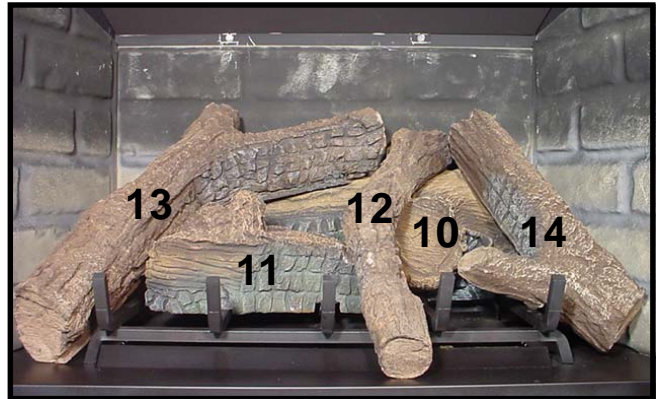

* Part number list on following page.

(NG) Service Parts List**6000TRS-CE**

IMPORTANT: THIS IS DATED INFORMATION. The most current information is located on your dealers VIP site. When ordering, supply serial and model numbers to ensure correct service parts.

ITEM	PARTS	SERIAL #	PART NUMBER
1	Junction Box		546-250A
2	Burner NG		2049-010
3	Glass Door Assembly		GLA-6TRXI
4	Log Grate		2049-020
5	Base Refractory		2049-102
6	Hood		SRV60-143-BK
7	Door Assembly		392-180A
8	Top Louver Assembly		392-182A
9	Log Set Assembly		LOGS-6TRSCE
10	Log 1		SRV2049-700
11	Log 2		SRV2049-701
12	Log 3		SRV385-723
13	Log 4		SRV385-721
14	Log 5		SRV385-722
15	Surround		2026-108
	Refractory Kit		BRICK-6000-FB
16	Back Wall Refractory		SRV2027-730
17	Left Wall Refractory		SRV2027-731
18	Right Wall Refractory		SRV2027-732
19	Insulation Board		385-401
20	Exhaust Baffle		2049-101
	Flue Gasket		2026-114
	Platinum Bright Embers		PBE-5
	Pilot Orifice NG		529-512
	Insulation Mineral Wool		050-721
ACCESSORIES			
	Extended Vertical Baffle Kit		BAF-VERT
	Wall Switch Kit, Off-white		WSK-21
	Wall Switch Kit, White		WSK-21-W
	Conversion Kit NG		NGK-6TRS-CE
	Conversion Kit LP		LPK-6TRS-CE
	Conversion Kit Butane		BGK-6TRS-CE

Also see following page for Standing Pilot valve assembly service part numbers.

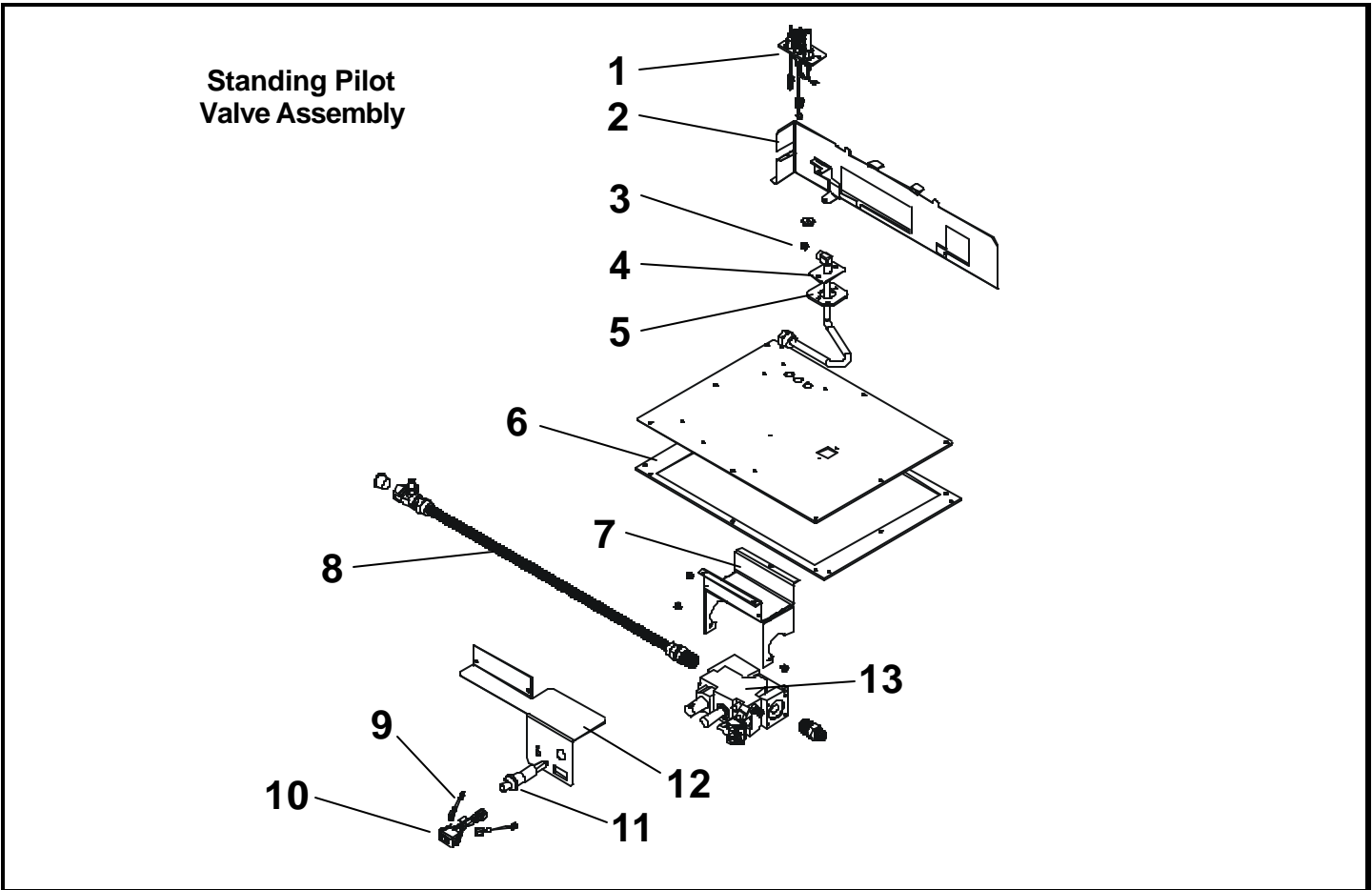

ITEM	DESCRIPTION	SERIAL #	PART NUMBER
1	Pilot Assembly NG		529-510A
2	Pilot Bracket		2049-105
3	Orifice NG (#33)		582-833
4	30.5 cm Flex		383-302A
5	Burner Neck Gasket		438-407
6	Valve Plate Gasket		385-402
7	Valve Bracket		2049-108
8	Flex Assembly		302-330A
9	Wire Assembly		049-552A
10	ON/Off Rocker Switch		060-521A
11	Piezo Ignitor		219-513
12	Control Panel		2049-109
13	S.I.T. Valve NG		060-524

Appliance Certification

The Heat-N-Glo fireplace models discussed in this *Installers Guide* have been tested to certification standards and listed by the applicable laboratories.

MODEL	LABORATORY	TYPE	CERTIFICATION STANDARD
6000TRS-CE	Advantica	Gas Fireplace	90/396/EEC

Installation Regulations

Before installation check that local distribution conditions, nature of gas and pressure, and adjustment of the appliance are compatible.

This appliance must be installed with the rules in force, and used only in a sufficiently ventilated space. Consult instructions before installation and use of this appliance.

1

Approvals and Regulations

2

Getting Started

Introducing the Heat-N-Glo Gas Fireplaces

Heat-N-Glo direct flue gas fireplaces are designed to operate with all combustion air siphoned from outside of the building and all exhaust gases expelled to the outside.

The information contained in this *Installers Guide*, unless noted otherwise, applies to all models and gas control systems.

Gas fireplace diagrams, including the dimensions, are shown in this section.

Pre-installation Preparation

This gas fireplace and its components are tested and safe when installed in accordance with this *Installers Guide*. Report to your dealer any parts damaged in shipment, particularly the condition of the glass. **Do not install any unit with damaged, incomplete, or substitute parts.**

The flue system components and trim doors are shipped in separate packages. The gas logs are packaged separately and must be field installed. **Read all of the instructions before starting the installation. Follow these instructions carefully during the installation to ensure maximum safety and benefit. Failure to follow these instructions will void the owner's warranty and may present a fire hazard.**

The Heat-N-Glo Fireplace Products, Inc. Warranty will be voided by, and Heat-N-Glo Fireplace Products, Inc. disclaims any responsibility for, the following actions:

- Installation of any damaged fireplace or flue system component.
- Modification of the fireplace or direct flue system.
- Installation other than as instructed by Heat-N-Glo Fireplace Products, Inc.
- Improper positioning of the gas logs or the glass door.
- Installation and/or use of any component part not manufactured and approved by Heat-N-Glo Fireplace Products, Inc., not withstanding any independent testing laboratory or other party approval of such component part or accessory.

ANY SUCH ACTION MAY POSSIBLY CAUSE A FIRE HAZARD.

When planning a fireplace installation, it's necessary to determine:

- Where the unit is to be installed.
- The flue system configuration to be used.
- Gas supply piping.
- Electrical wiring.
- Framing and finishing details.
- Whether optional accessories—devices such as a fan, wall switch, or remote control—are desired.

If the fireplace is to be installed on carpeting or tile, or on any combustible material other than wood flooring, the fireplace should be installed on a metal or wood panel that extends the full width and depth of the fireplace.

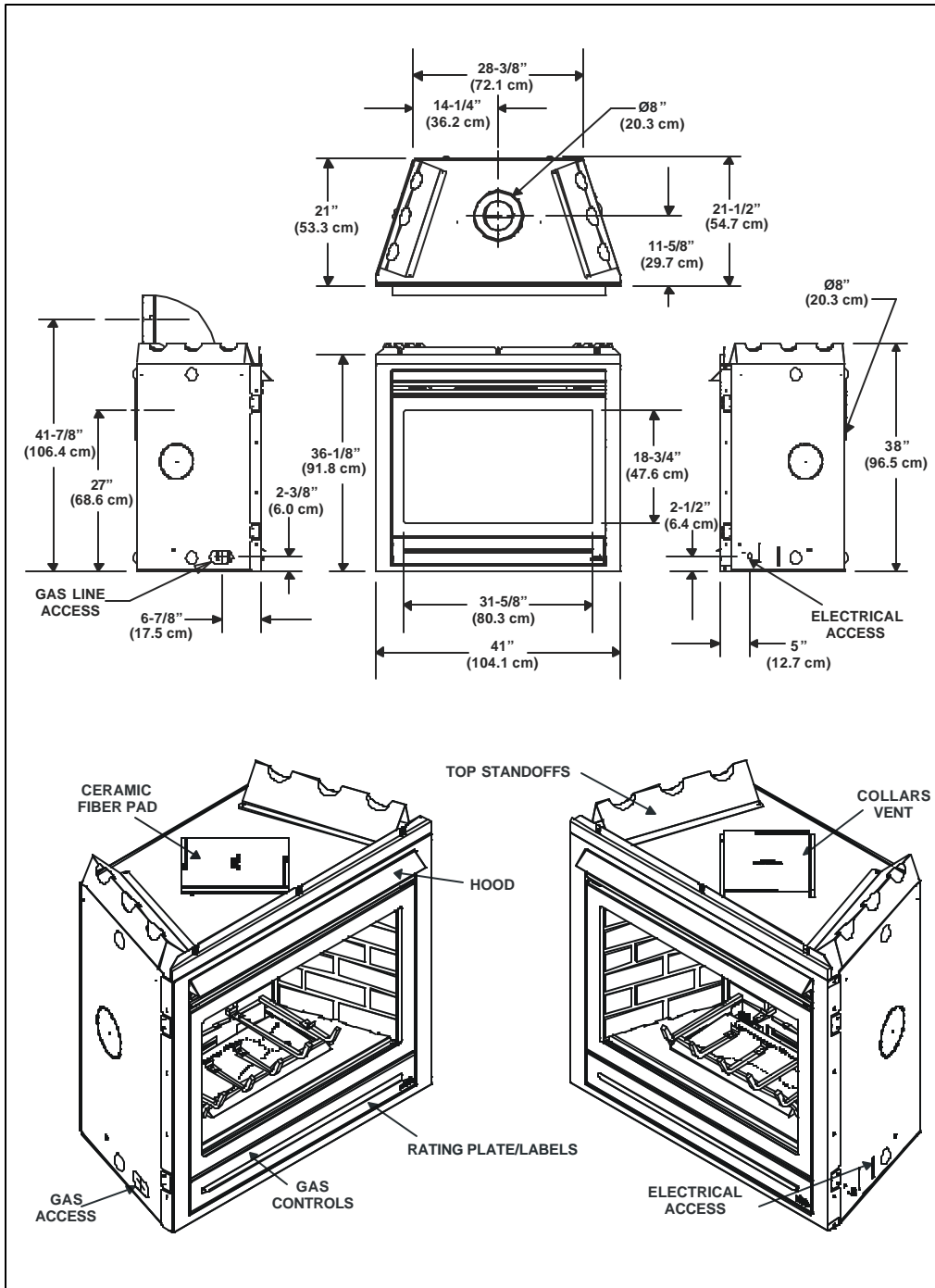

Figure 1. Diagram of the 6000TRS-CE

3

Installing the Fireplace

Step 1 Locating the Fireplace

The diagram below shows space and clearance requirements for locating a fireplace within a room.

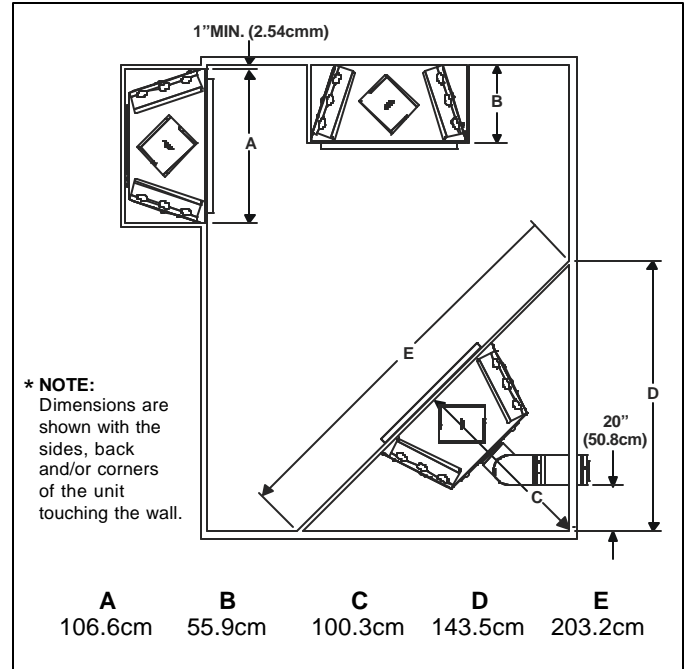

Figure 2. Fireplace Dimensions, Locations, and Space Requirements

Clearance Requirements

The top and back of the fireplace are defined by stand-offs.

The minimum clearance to a perpendicular wall extending past the face of the fireplace is 7.62cm.

The back of the fireplaces may be recessed into combustible construction (see Figure 3).

MODEL: 6000TRS-CE			RECESSED DEPTH: 54.6cm			
Minimum Clearances from the Fireplace to Combustible Materials						
<i>Glass Front</i>	<i>Floor</i>	<i>Back of Fireplace</i>	<i>Sides of Fireplace</i>	<i>Top of Fireplace</i>	<i>Ceiling</i>	
91.4cm	0	1.3cm	1.3cm	8.9cm	79cm	
Minimum Clearances from the Flue Pipe to Combustible Materials						
<i>For Horizontal Sections</i>			<i>For Vertical Sections</i>	<i>At Wall Firestops</i>		
Top	Bottom	Sides		Top	Bottom	Sides
7.6cm	2.54 cm	2.54 cm	2.54 cm	6.4 cm	1.3 cm	2.54 cm

Figure 3. Minimum Clearances

Step 2 Framing the Fireplace

Fireplace framing can be built before or after the fireplace is set in place. Framing should be positioned to accommodate wall coverings and fireplace facing material. The diagram below shows framing reference dimensions.

CAUTION

MEASURE FIREPLACE DIMENSIONS, AND VERIFY FRAMING METHODS AND WALL COVERING DETAILS, BEFORE FRAMING CONSTRUCTION BEGINS.

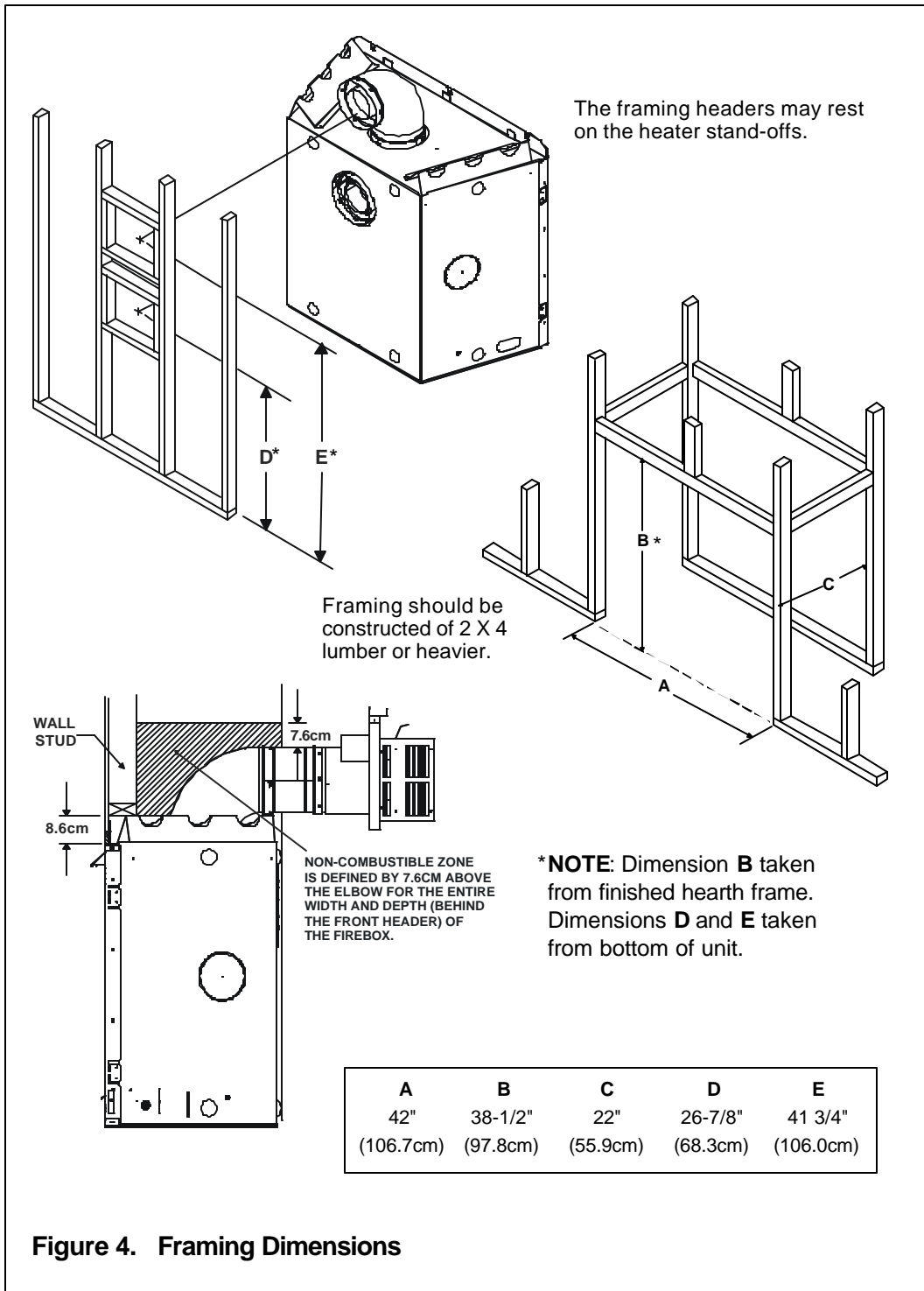

Figure 4. Framing Dimensions

Step 3 Installing the Flue System

A. Flue System Approvals

These models have flue starting collars on both the top and the back of the unit. Depending upon the installation, decide which ONE set of starting collars will be used to attached the flue system. The starting collar sealing cap must remain on the starting collar NOT used.

These models use DVP-series direct flue components when using the **TOP and REAR** flue collars.

Approved flue system components are labeled for identification. **NO OTHER FLUEING SYSTEMS OR COMPONENTS MAY BE USED**. Detailed installation instructions are included with each flue termination kit and should be used in conjunction with this *Installers Guide*. Figure 4 shows flue system components and terminations.

Identifying Flue Components

The flue systems installed on this gas fireplace may include one, two, or three 90° elbow assemblies. The relationships of vertical rise to horizontal run in flue configurations using 90° elbows **MUST BE** strictly adhered to. The rise to run relationships are shown in the flueing drawings and tables on the next several pages.

NOTE: Two 45° elbows may be used in place of one 90° elbow. You **MUST** always maintain the **MAXIMUM** and **MINIMUM** rise-to-run ratios in the flue system when using 45° elbows.

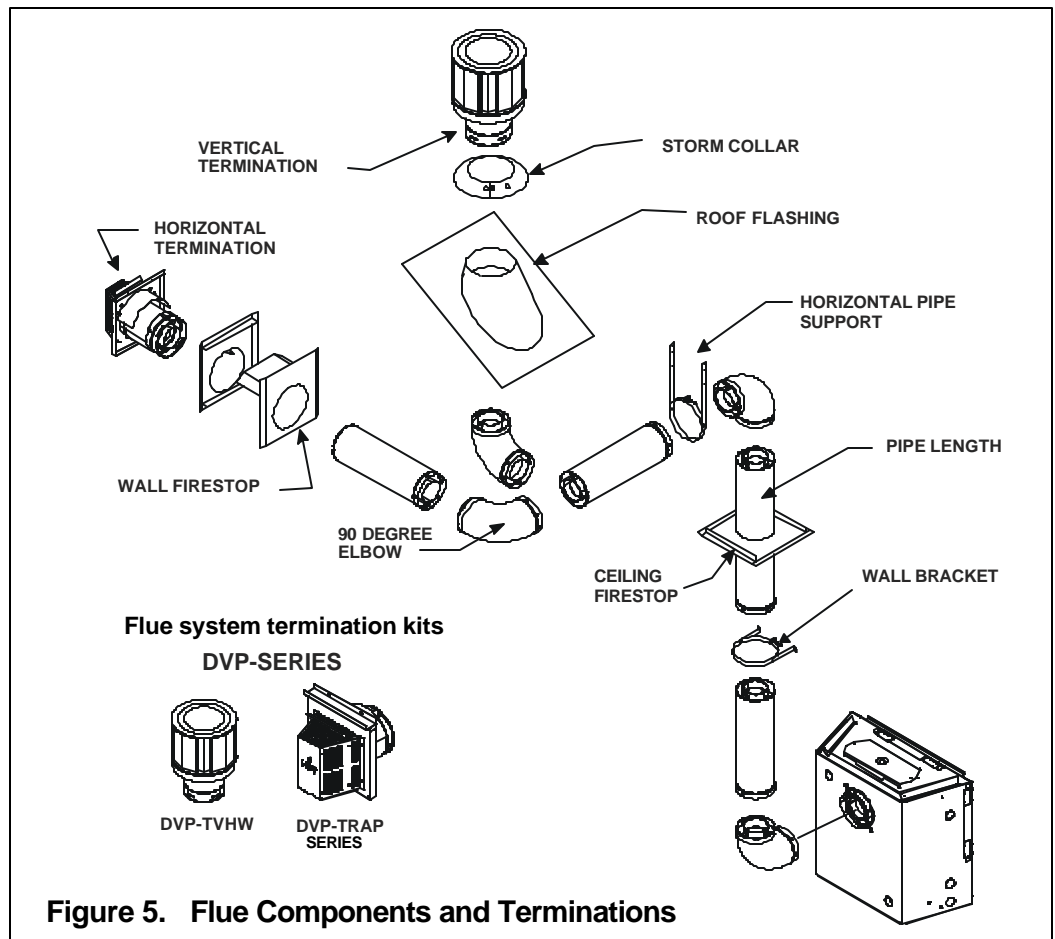

Figure 5. Flue Components and Terminations

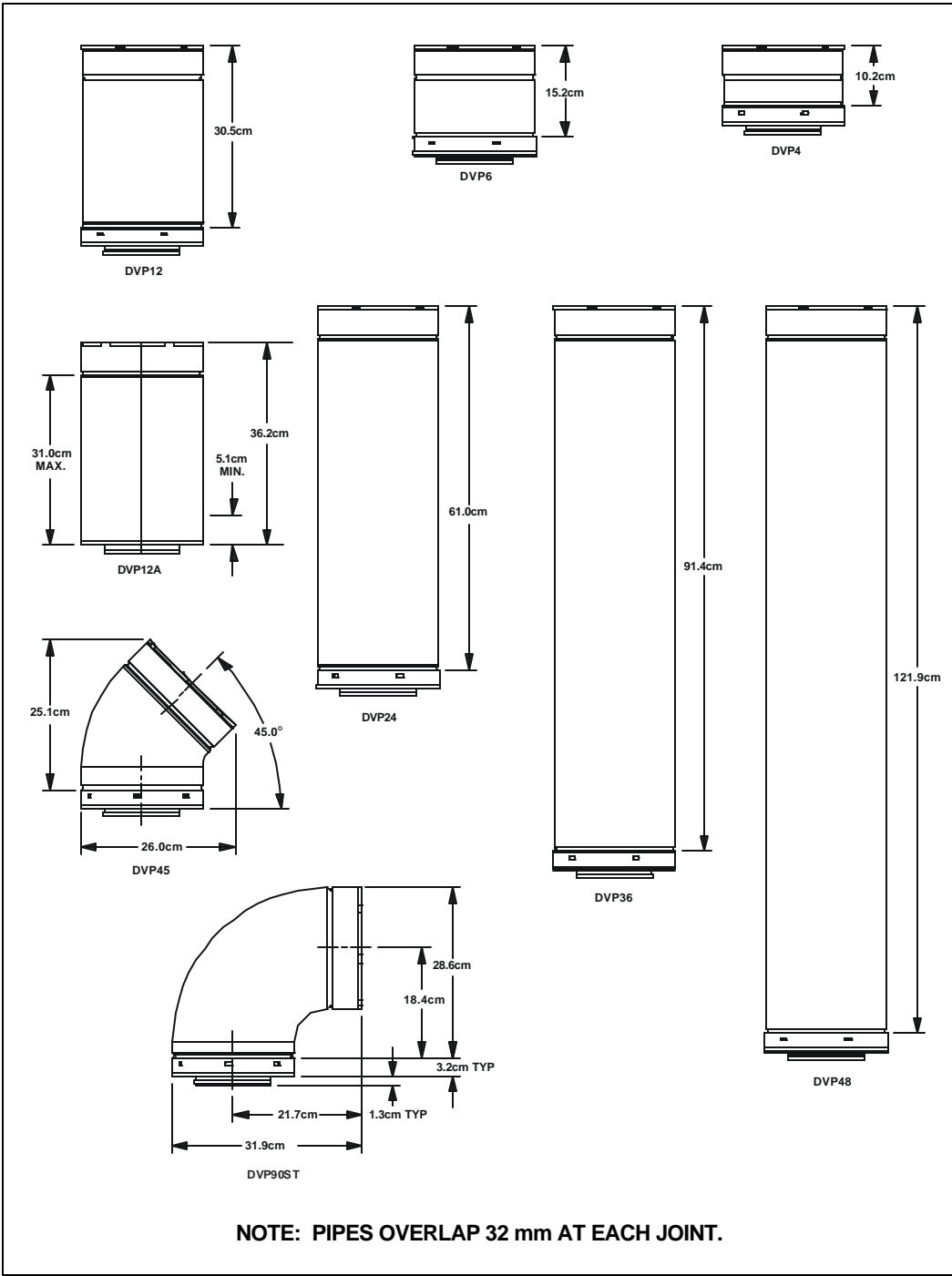
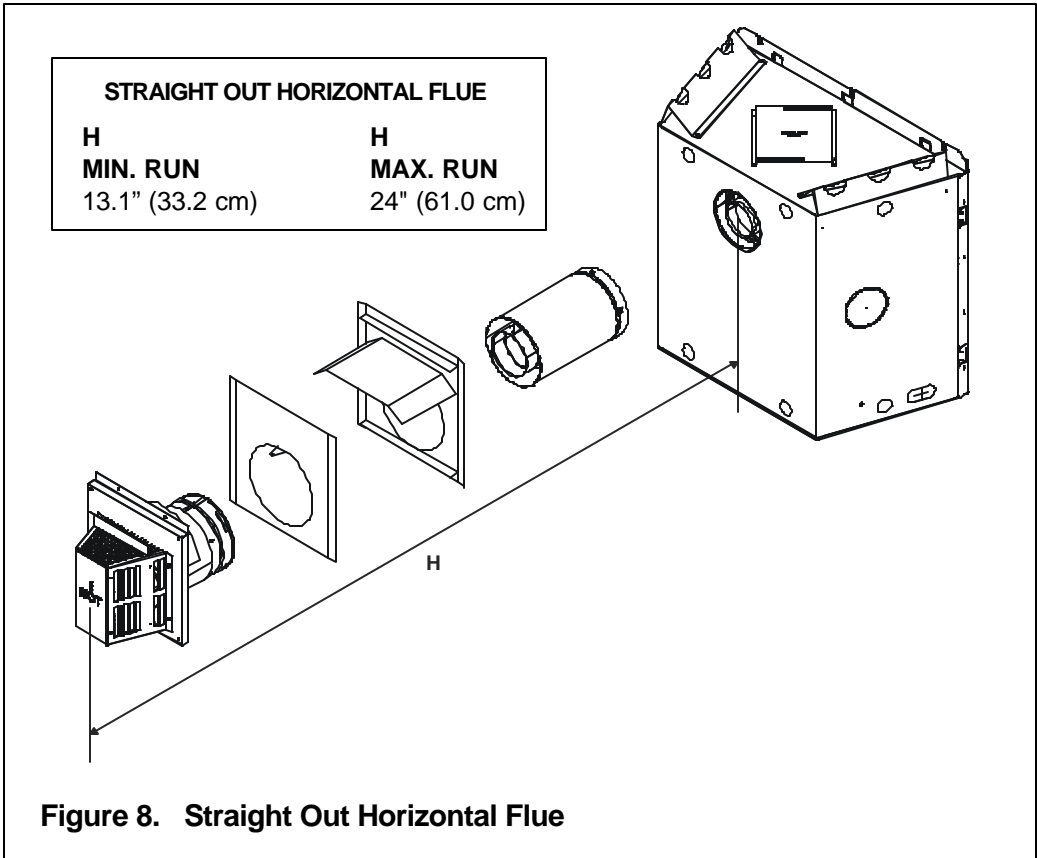
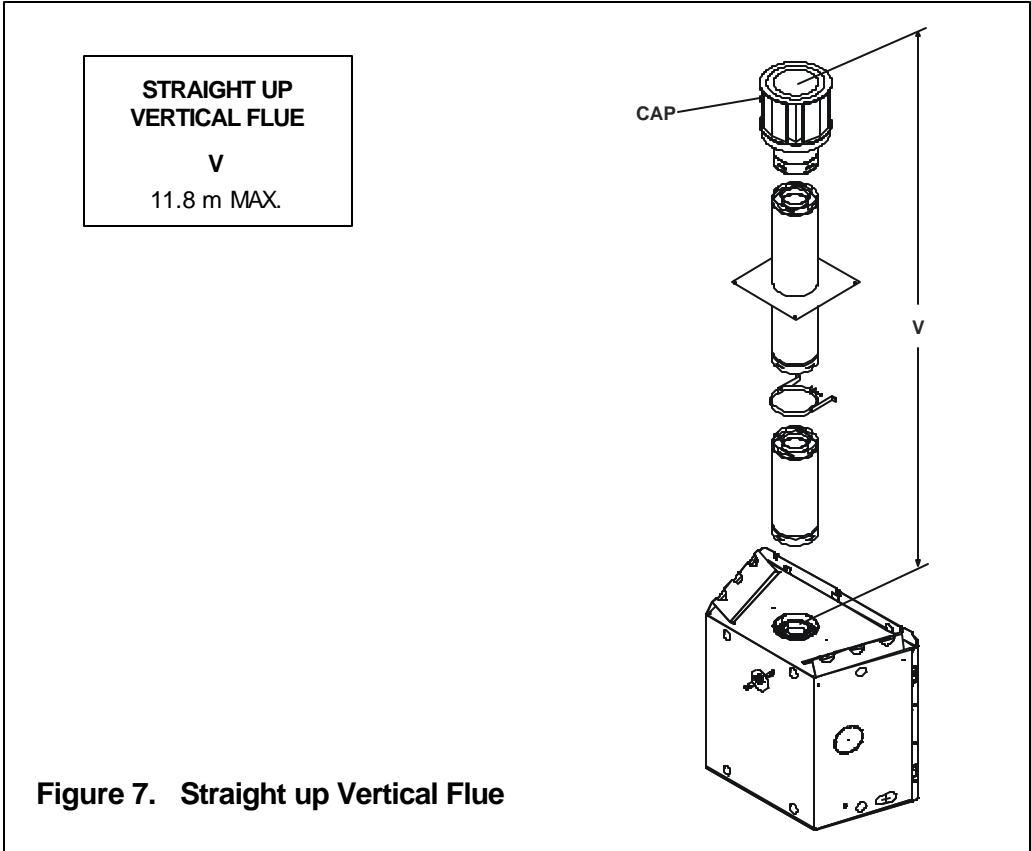
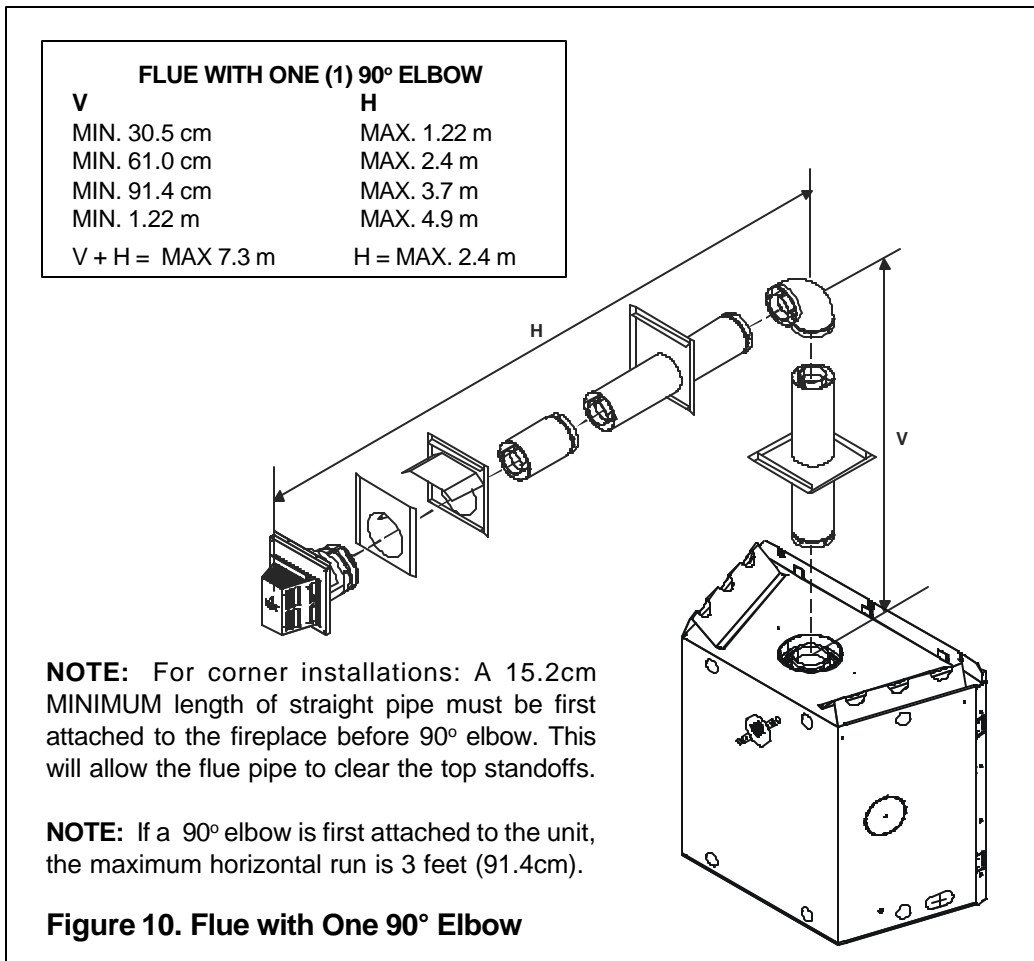
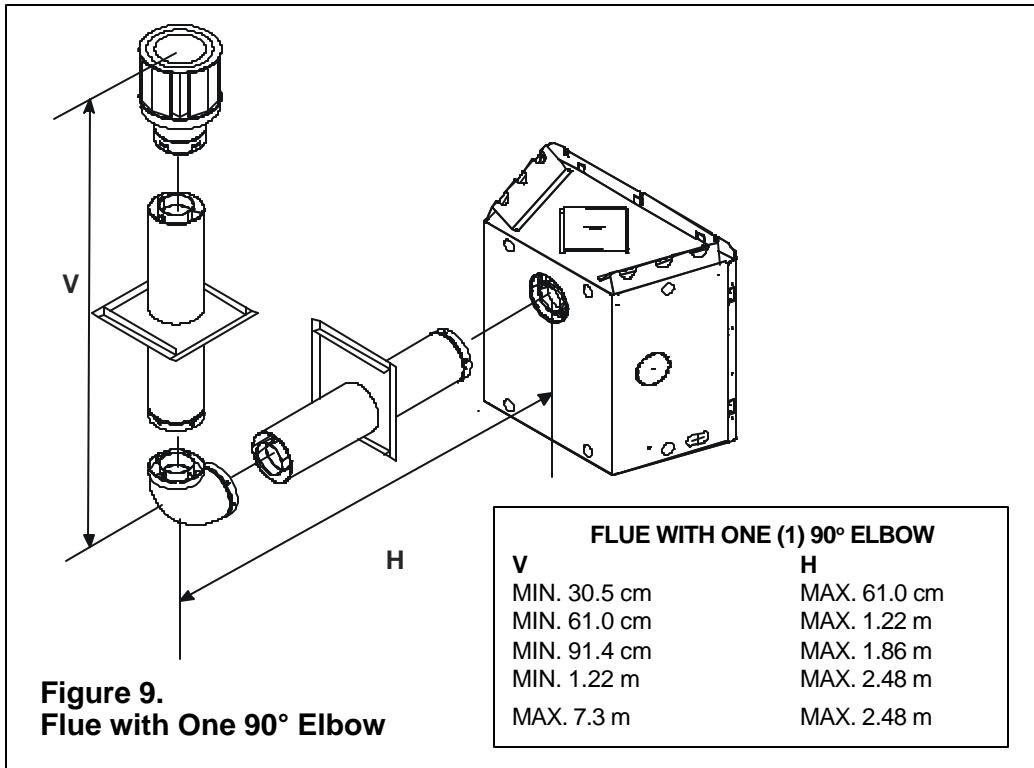

FIGURE 6. DVP-Series Balanced Flue Component Specifications (127 mm inner pipe / 203 mm outer pipe)





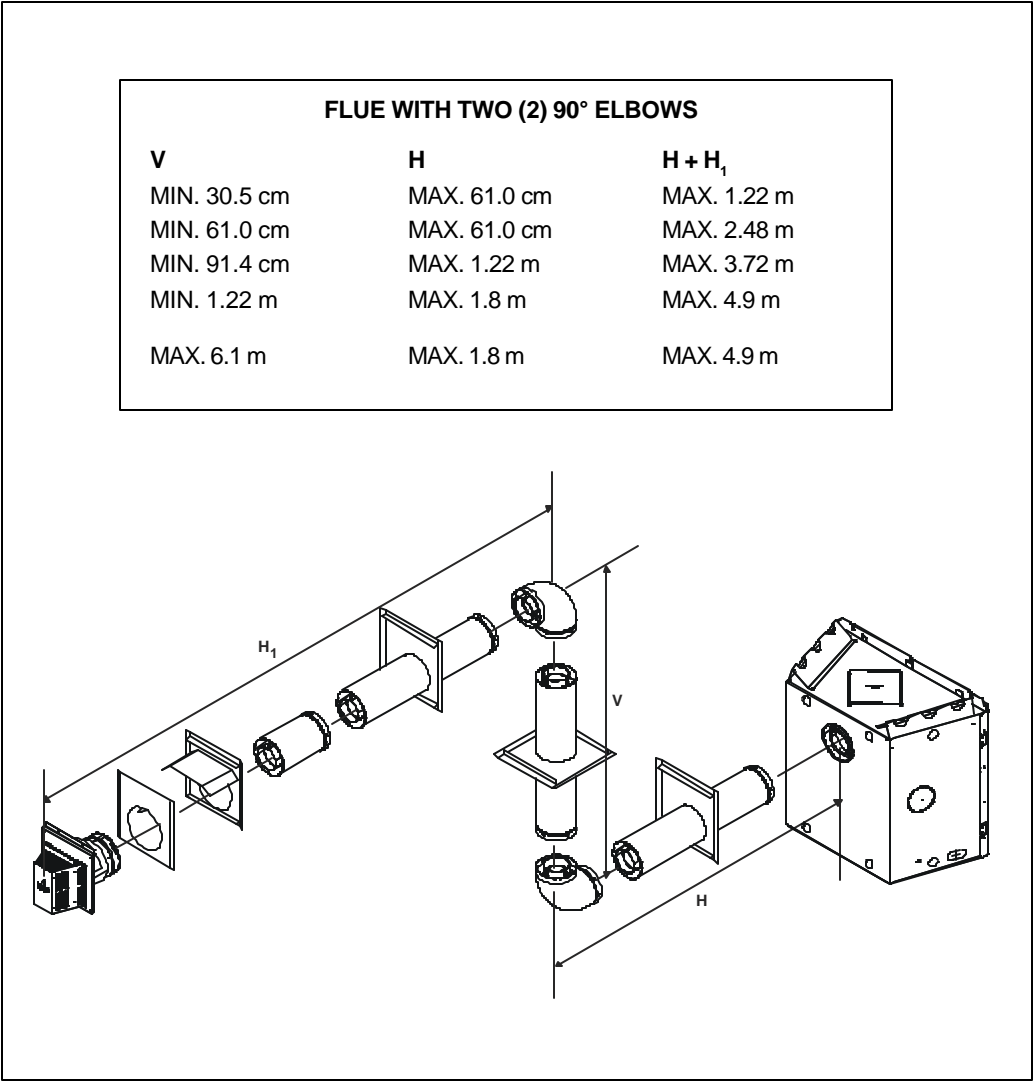

Figure 11. Flue with Two 90° Elbows

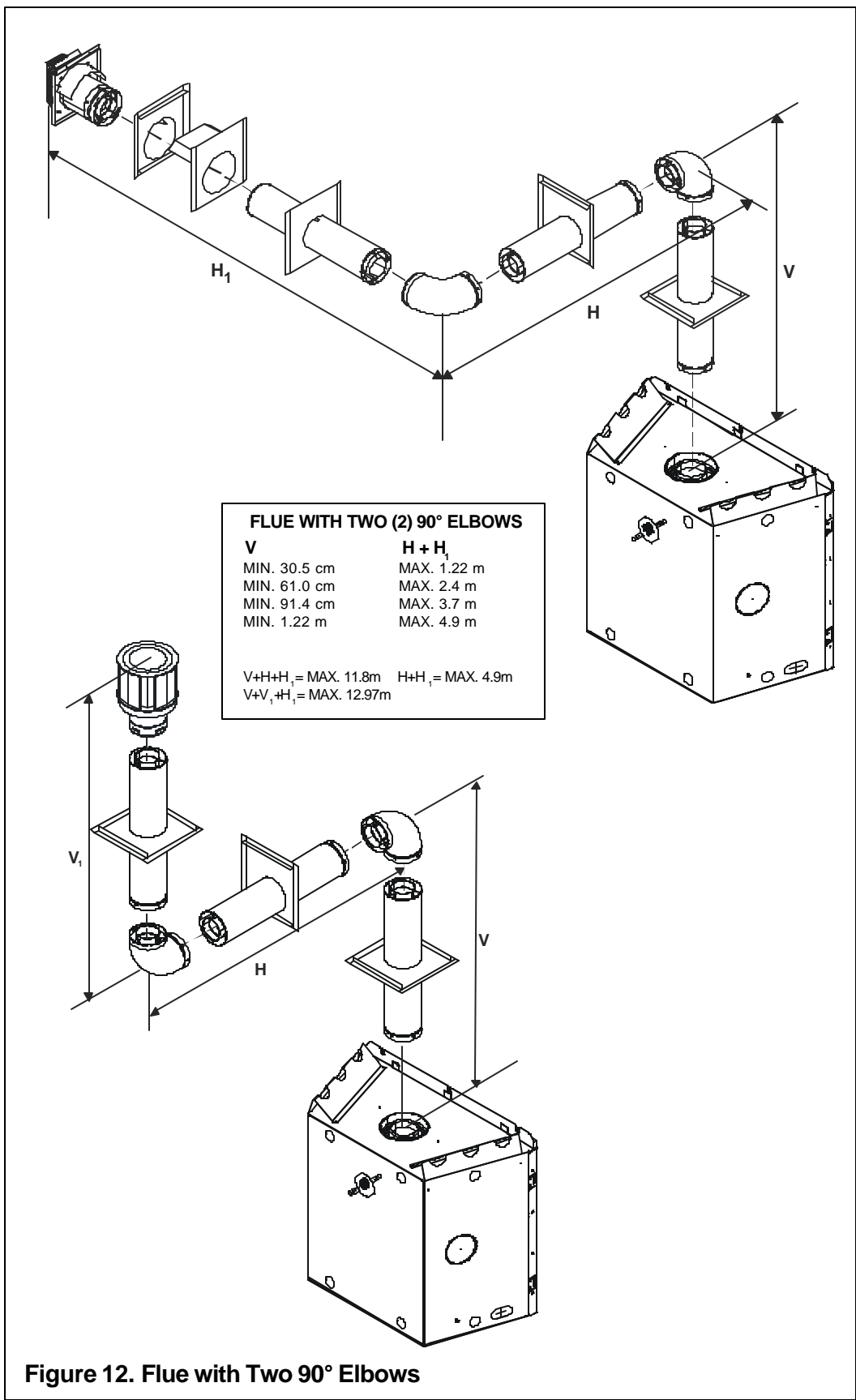

Figure 12. Flue with Two 90° Elbows

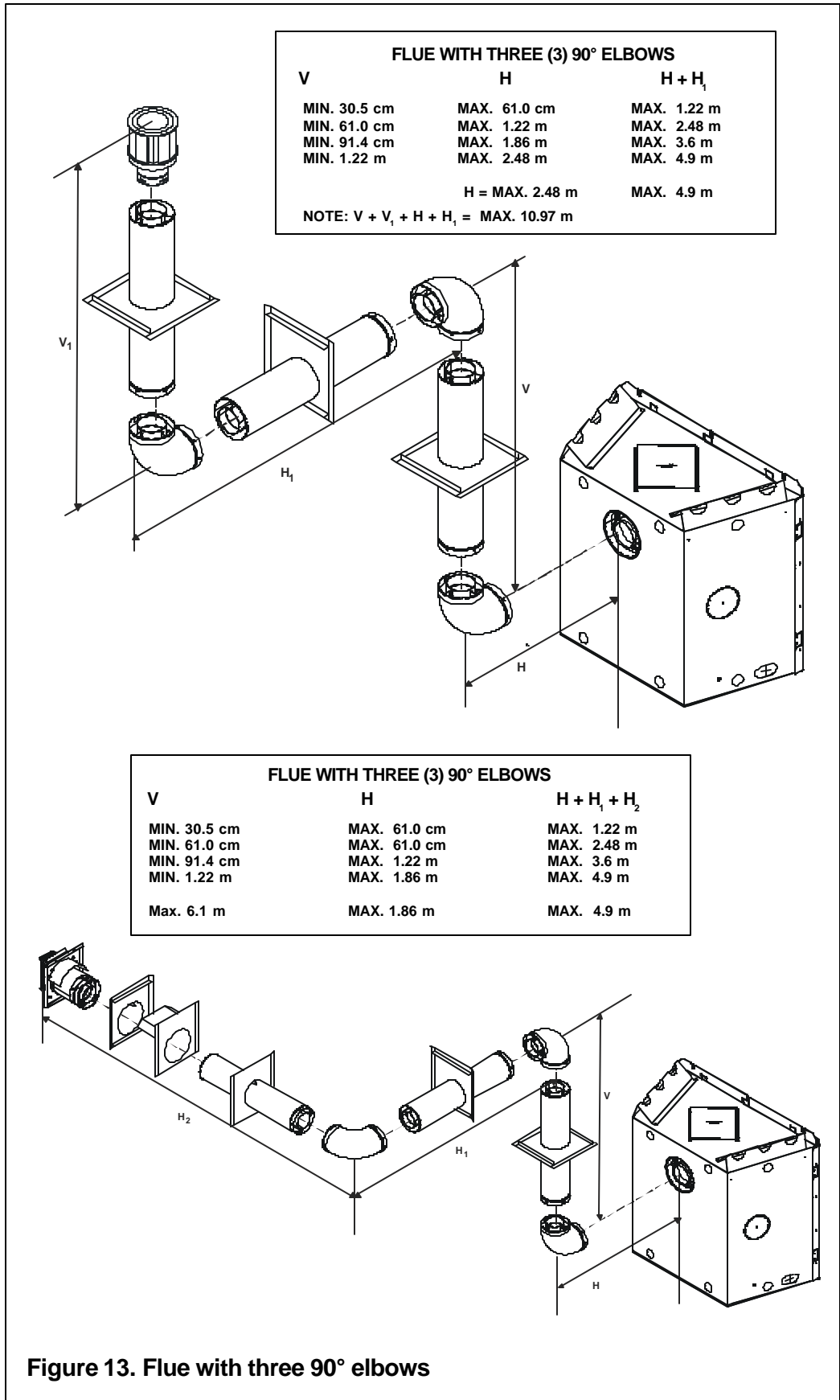
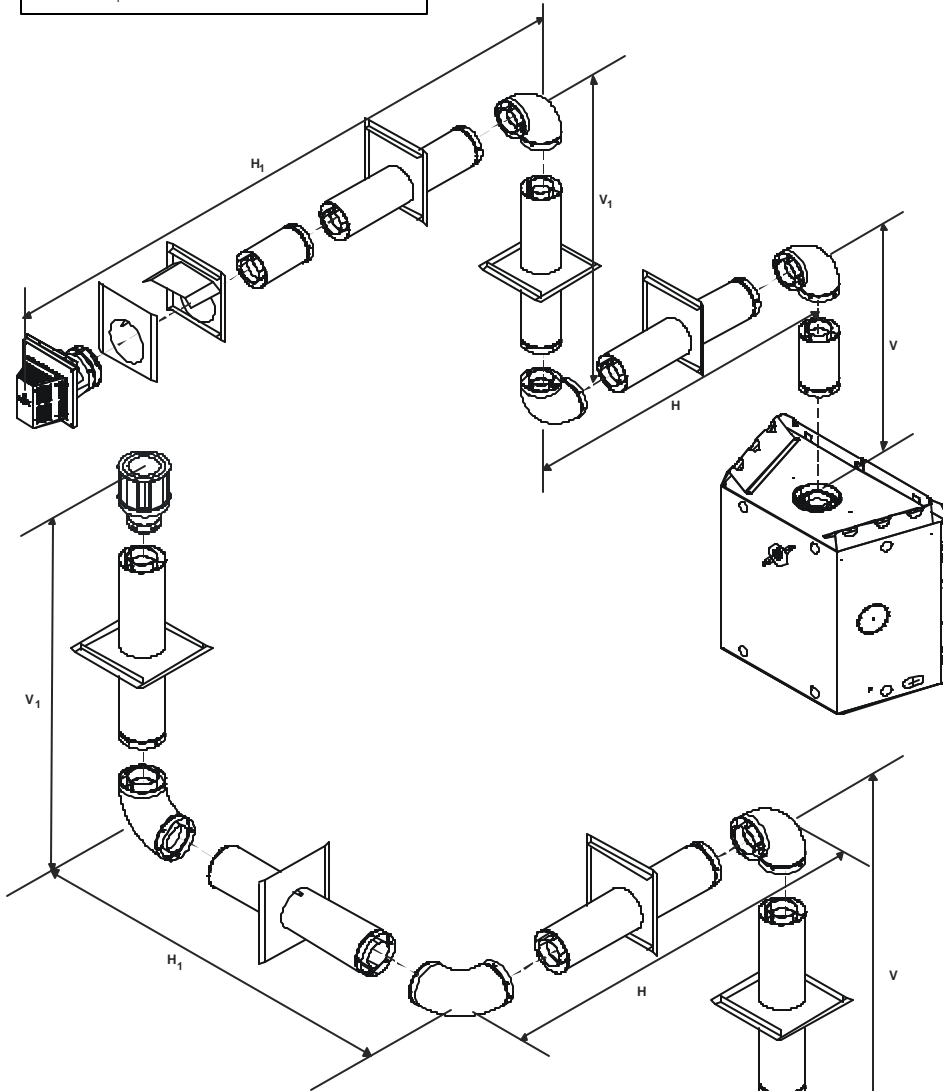

Figure 13. Flue with three 90° elbows

FLUE WITH THREE (3) 90° ELBOWS

V	H + H ₁
MIN. 30.5 cm	MAX. 1.22 m
MIN. 61.0 cm	MAX. 2.4 m
MIN. 91.4 cm	MAX. 3.7 m
MIN. 1.22 m	MAX. 4.9 m

V + V₁ + H + H₁ = MAX. 10.97 m
 H + H₁ = MAX. 4.9 m



FLUE WITH THREE (3) 90° ELBOWS

V	H + H ₁
MIN. 30.5 cm	MAX. 1.22 m
MIN. 61.0 cm	MAX. 2.4 m
MIN. 91.4 cm	MAX. 3.7 m
MIN. 1.22 m	MAX. 4.9 m

V + V₁ + H + H₁ = MAX. 10.97 m
 H + H₁ = MAX. 4.9 m

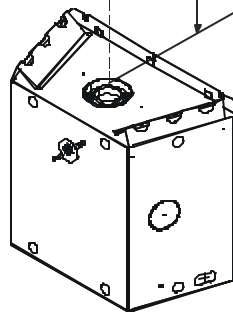

Figure 14. Flue with three 90° elbows

B. Installing Flue Components

After determining which set of starting collars will be used (top or rear), follow venting instructions accordingly.

Venting Out the Rear Flue

Remove the installed rear seal cap from the rear starting collars by cutting the strap at each end (See Figure 15). Follow the flue configuration tables accordingly.

Remove the 12.7cm diameter heat shield from the 1.27cm diameter collar by sliding it out. Remove insulation piece.

! WARNING: THE TOP HEAT SHIELD (INSIDE THE FIREBOX) MUST REMAIN ATTACHED IF THE FLUE SYSTEM IS ATTACHED TO THE REAR STARTING COLLARS. SEE FIGURE 15.

Venting Out the Top Flue

Remove the top flue collar seal cap by cutting the strap on each end. Remove both pieces of insulation inside the top two starting collars (see Figure 15).

Remove the 10.2cm diameter heat shield from the 10.2cm diameter collar by sliding it out.

You have to take the glass off again for positioning the logs when the unit is finally installed in place and finished around it. Reinstall the glass door. Attach flue system to the top starting collars.

! WARNING: THE REAR FLUE COLLAR SEAL CAP MUST REMAIN ATTACHED TO THE REAR FLUE COLLARS IF THE FLUE SYSTEM IS ATTACHED TO THE TOP STARTING COLLARS. SEE FIGURE 15.

! WARNING: FAILURE TO REMOVE INSULATION IN THE SET OF COLLARS YOU ARE USING COULD CAUSE A FIRE.

! WARNING: YOU MUST LEAVE THE INSULATION IN PLACE IN THE SET OF COLLARS YOU ARE NOT USING.

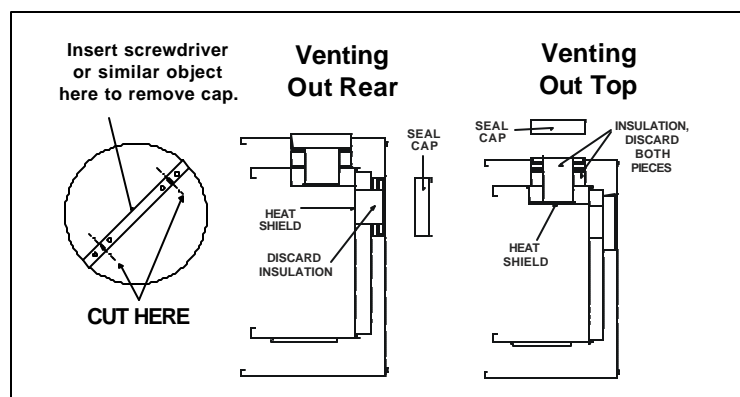

Figure 15

Installing Flue Components

1. Attaching the First Flue Component to the Starting Collars:

A. On the REAR of the heater

- To attach the first flue component to the starting collars on the rear of the heater make sure that the heater gasket supplied with the heater seals between the first flue component and the outer heater wrap.
- The first 90° elbow installed in the flue system of a rear flueing heater **MUST BE** in a vertical position.

B. On the TOP of the heater

To attach the first flue component to the starting collars on the top of the heater:

- Slide the male end of the inner flue of the pipe section into the inner collar on the heater. At the same time, insert the outer flue into the outer collar on the heater. Push the flue section into the appliance collar until all the lances (see Figure 16) have snapped in place. Tug slightly on the flue to confirm that it has completely locked into place.
- Slide the ceramic fiber pad over the first flue section and place it flush to the fireplace. Continue to add vent components.

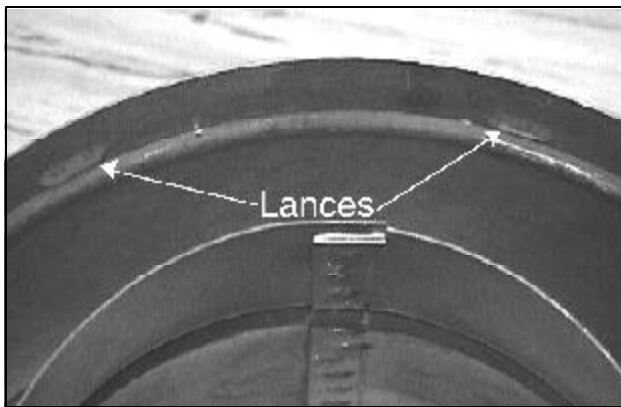

FIGURE 16.

WARNING: ENSURE THAT THE HEATER GASKET SUPPLIED WITH THE HEATER SEALS BETWEEN THE FIRST FLUE COMPONENT AND THE OUTER HEATER WRAP.

C. Continue Adding Flue Components

To continue adding flue components in accordance with the pre-planned flue system configuration:

- Ensure that each succeeding flue component is securely fitted and locked into the preceding component in the flue system. **NOTE:** Make sure that seams are **NOT** aligned to prevent unintentional disconnection.
- For elbows that are changing the flue direction, two screws minimum should be put in the outer flue at the joint to prevent the elbow from rotating.

2. Install Support Brackets

For Horizontal Runs - The flue system must be supported every five (5) feet (152.4 cm) of horizontal run by a horizontal pipe support.

To install support brackets for horizontal runs:

- Place the pipe supports around the flue pipe.

For Vertical Runs - The flue system must be supported every 240 cm above the heater flue outlet by wall brackets.

To install support brackets for vertical runs:

- Attach wall brackets to the flue pipe and secure the wall bracket to the framing members with nails or screws.

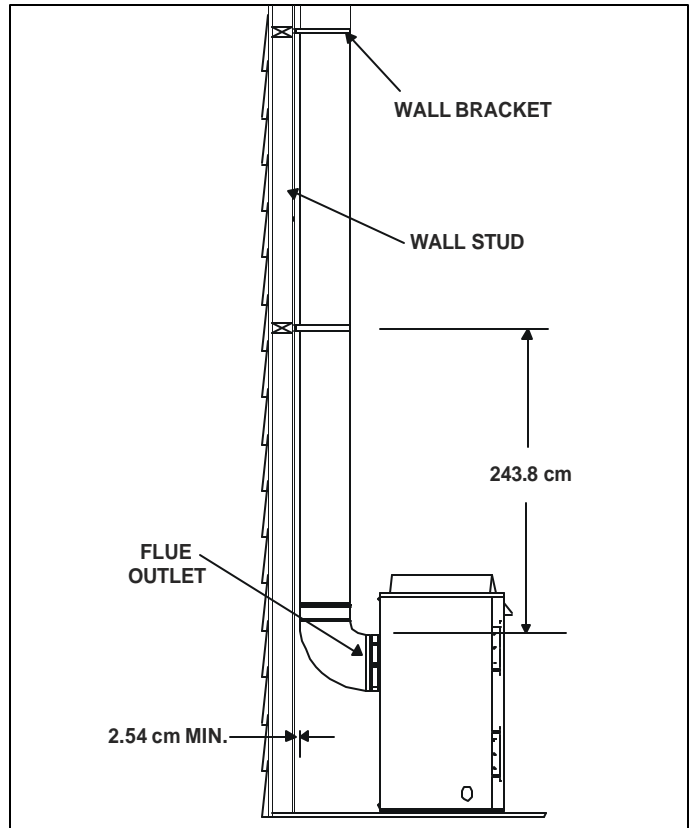

Figure 17. Installing Support Brackets

3. Install Firestops

For Horizontal Runs - Firestops are **REQUIRED** on both sides of a combustible wall through which the flue passes.

To install firestops (heat shield) for horizontal runs that pass through either interior or exterior walls:

- Cut a 25.4 cm X 30.5 cm hole through the wall.
- Position the firestops on both sides of the hole previously cut and secure the firestops with nails or screws.
- The pipe opening of the firestops **MUST BE** placed towards the bottom of the firestop.
- Continue the flue run through the firestop.

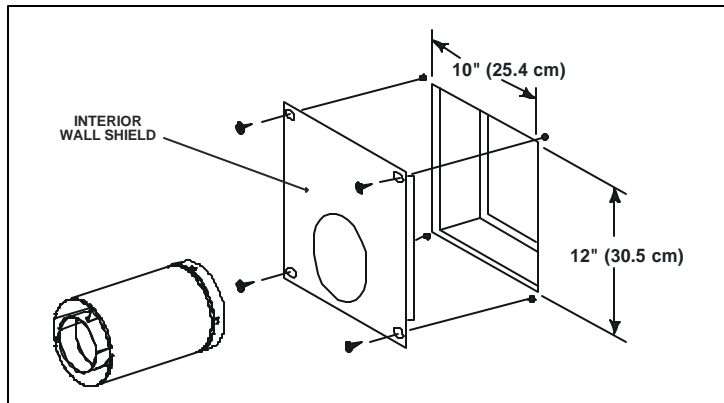

FIGURE 18. Flue Pipe & Firestop

For Vertical Runs - One firestop is **REQUIRED** at the hole in each ceiling through which the flue passes.

To install firestops for vertical runs that pass through ceilings:

- Position a plumb bob directly over the center of the vertical flue component.
- Mark the ceiling to establish the centerpoint of the flue.
- Drill a hole or drive a nail through this center point.
- Check the floor above for any obstructions, such as wiring or plumbing runs.
- Reposition the heater and flue system, if necessary, to accommodate the ceiling joists and/or obstructions.
- Cut a 25.4cm X 30.5cm hole through the ceiling, using the firestop pipe opening as a guide.
- Frame the hole with framing lumber the same size as the ceiling joists.

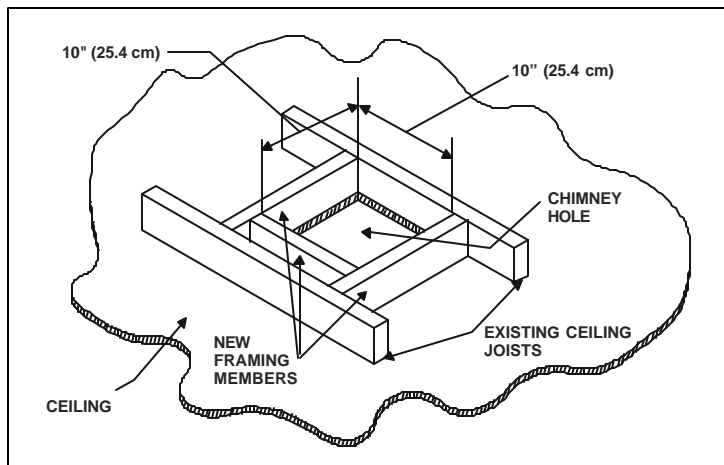

FIGURE 19. Hole and New Framing Members

If the area above the ceiling is **NOT** an attic, position and secure the ceiling firestop on the ceiling side of the previously cut and framed hole.

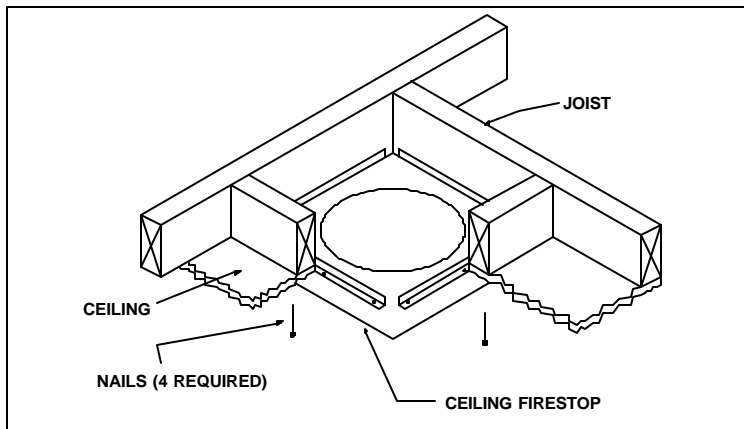

FIGURE 20. Ceiling Firestop (Ceiling Side)

If the area above the ceiling **IS** an attic, position and secure the firestop on top of the previously framed hole.

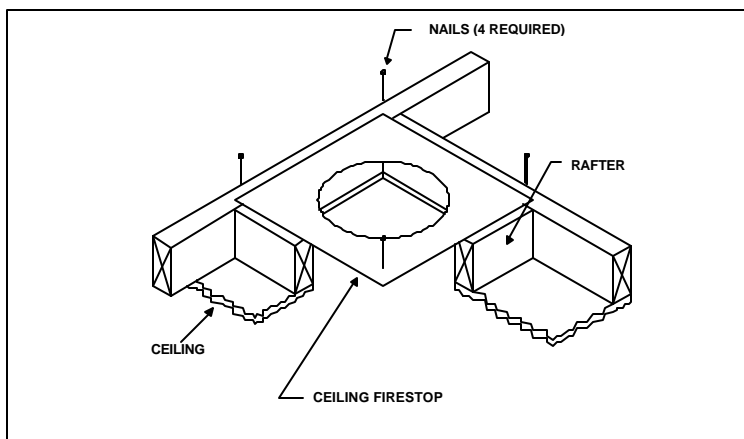

FIGURE 21. Attic Firestop

C. Flue Termination

CAUTION:

IF EXTERIOR WALLS ARE FINISHED WITH VINYL SIDING, IT IS NECESSARY TO INSTALL THE VINYL PROTECTOR KIT (VPK-DV) TO THE TOP OF THE EXTERIOR FIRESTOP FOR ALL ROUND TERMINATION CAPS.

For Horizontal Terminations using the DVP-TRAP

To attach and secure the termination to the last section of horizontal flue:

- The rear flue heat shield **MUST** be placed 2.54 cm above the top of the flue between the wall shield and the base of the termination cap.
- One section of the heat shield is attached to the wall shield. The other is attached to the termination cap in the same manner (see Figure 22).

- The heat shield sections will overlap to match the wall thickness (depth). The small leg in the shield rests on top of the flue to properly space it from the pipe section (see Figure 22).

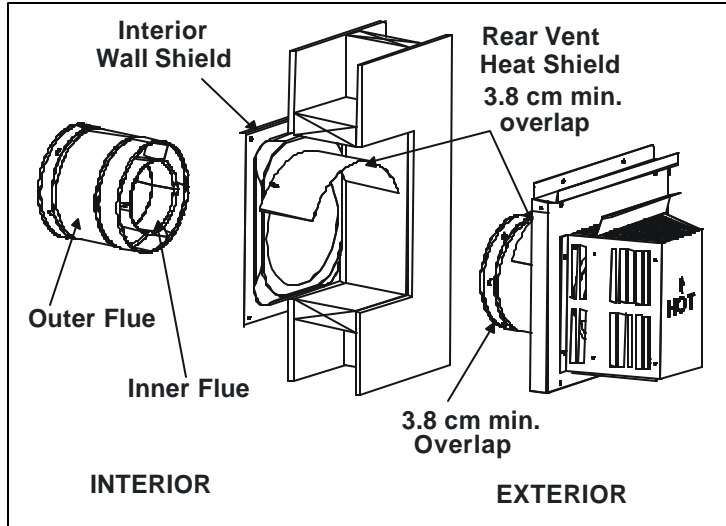

FIGURE 22. Venting through the Wall

- The termination kit should pass through the wall firestops from the exterior of the building.
- Adjust the termination cap to its final exterior position on the building and interlock the flue sections.



WARNING: THE TERMINATION CAP MUST BE POSITIONED SO THAT THE ARROW IS POINTING UP.

- Use a high-temperature sealant gasket to seal between the pipe and exterior firestop.

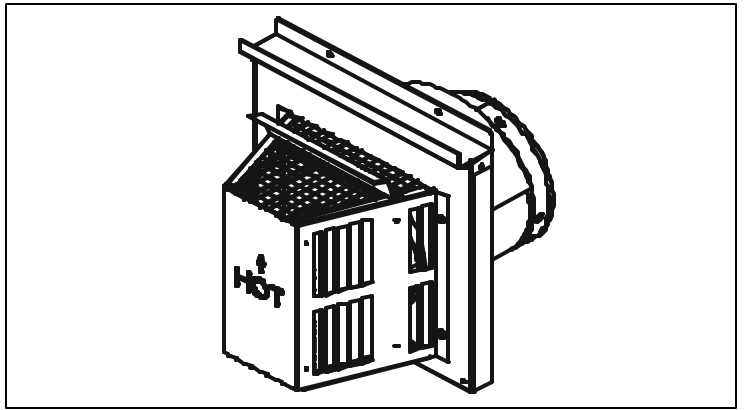

FIGURE 23 DVP Termination Cap

For Vertical Terminations - To locate the flue and install the flue sections:

- Locate and mark the flue centerpoint on the underside of the roof, and drive a nail through the centerpoint.
- Make the outline of the roof hole around the centerpoint nail.
- The size of the roof hole framing dimensions depend on the pitch of the roof. There **MUST BE** a 2.5cm clearance from the vertical flue pipe to combustible materials.
- Mark the roof hole accordingly.
- Cover the opening of the installed flue pipes.
- Cut and frame the roof hole.
- Use framing lumber the same size as the roof rafters and install the frame securely. Flashing anchored to the frame must withstand heavy winds.
- Continue to install concentric flue sections up through the roof hole and up past the roof line until you reach the appropriate distance above the roof.

CAUTION: FOLLOW THE REQUIREMENTS OF THE AGA GAS INSTALLATION CODE FOR MINIMUM HEIGHT REQUIREMENTS ABOVE THE ROOF.

To seal the roof hole, and to divert rain and snow from the flue system:

- Attach a flashing to the roof using nails, and use a non-hardening mastic around the edges of the flashing base where it meets the roof.
- Attach a storm collar over the flashing joint to form a water-tight seal. Place non-hardening mastic around the joint, between the storm collar and the vertical pipe.
- Slide the termination cap over the end of the flue pipe and snap into place.



WARNING:
FOLLOW NATIONAL REGULATIONS
AND CODES OF PRACTICE FOR
MINIMUM CLEARANCES FROM GAS
TERMINALS, AND PLACEMENT OF GAS
TERMINAL.

NOTE

This also pertains to vertical flue systems installed on the outside of the building.

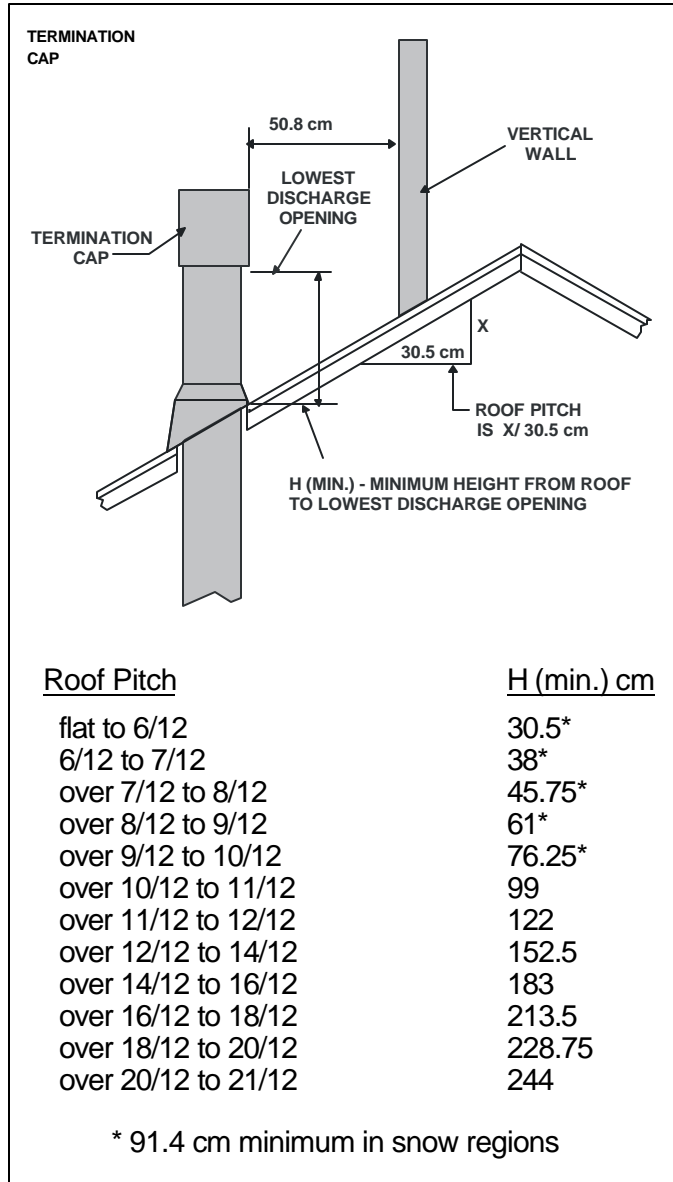
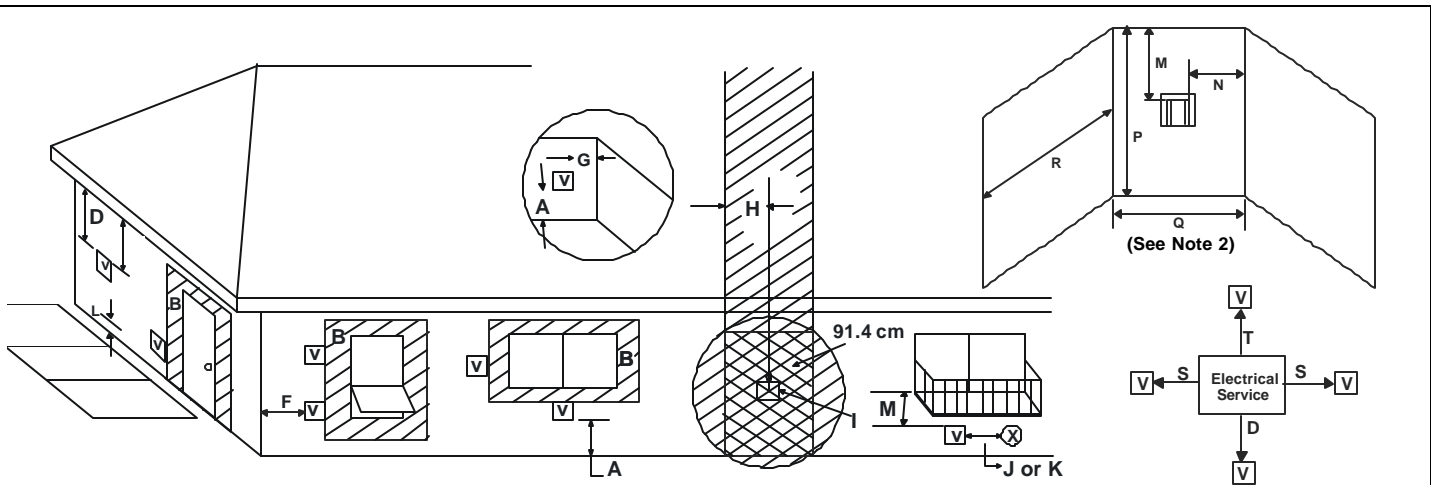

Figure 24. Minimum Height from Roof to Lowest Discharge Opening



V = VENT TERMINAL **X** = AIR SUPPLY INLET **Hatched Area** = AREA WHERE TERMINAL IS NOT PERMITTED

- A = 30.5 cm clearances above grade, veranda, porch, deck or balcony (See Note 1)
- B = 30.5 cm clearances to window or door that may be opened, or to permanently closed window. (Glass)
- D = 50.8 cm vertical clearance to unventilated soffit or to ventilated soffit located above the terminal
= 84.8 cm for vinyl clad soffits and below electrical service
- F = 22.9 cm clearance to outside corner
- G = 15.3 cm clearance to inside corner
- H = 91.4 cm not to be installed above a gas meter/regulator assembly within 91.4 cm horizontally from the center-line of the regulator
- I = 91.4 cm clearance to gas service regulator vent outlet
- J = 22.9 cm clearance to non-mechanical air supply inlet to building or the combustion air inlet to any other appliance
- K = 91.4 cm clearance to a mechanical (powered) air supply inlet

- L = 2.1 M clearance above paved sidewalk or a paved driveway located on **public** property (See Note 1)
- M* = 50.8 cm clearance under veranda, porch, deck, balcony or overhang
118.9 cm vinyl

Alcove Applications		
N	15.3 cm	non-vinyl sidewalls
	30.5 cm	vinyl sidewalls
P	2.4 M	
	Q_{MIN}	R_{MAX}
1 cap	91.4 cm	2 x Q _{ACTUAL}
2 caps	1.8 M	1 x Q _{ACTUAL}
3 caps	2.7 M	2/3 x Q _{ACTUAL}
4 caps	3.7 M	1/2 x Q _{ACTUAL}
Q_{MIN} = # termination caps x 3 R_{MAX} = (2 / # termination caps) x Q _{ACTUAL}		

- S = 15.3 cm clearance from sides of electrical service (See Note 5)
- T = 30.5 cm clearance above electrical service (See Note 5)

* only permitted if veranda, porch, deck or balcony is fully open on a minimum of 2 sides beneath the floor, or meets Note 2.

NOTE 1: On private property where termination is less than 2.1 M above a sidewalk, driveway, deck, porch, veranda or balcony, use of a listed cap shield is suggested. (See vents components page)

NOTE 2: Termination in an alcove space (spaces open only on one side and with an overhang) are permitted with the dimensions specified for vinyl or non-vinyl siding and soffits. **1.** There must be 91.4 cm minimum between termination caps. **2.** All mechanical air intakes within 3.0 M of a termination cap must be a minimum of 91.4 cm below the termination cap. **3.** All gravity air intakes within 91.4 cm of a termination cap must be a minimum of 30.5 cm below the termination cap.

Figure 25 Vent Termination Minimum Clearances

NOTE 3: Local codes or regulations may require different clearances.

NOTE 4: Termination caps may be hot. Consider their proximity to doors or other traffic areas.

NOTE 5: Location of the vent termination must not interfere with access to the electrical service.

NOTE: Vent system termination is permitted in porch areas with two or more sides open. You must follow all side walls, overhang and ground clearances as stated in the instructions.

Heat-N-Glo assumes no responsibility for the improper performance of the appliance when the venting system does not meet these requirements.

CAUTION: IF EXTERIOR WALLS ARE FINISHED WITH VINYL SIDING IT IS SUGGESTED THAT A VINYL PROTECTOR KIT BE INSTALLED.

Step 4 Positioning, Leveling, and Securing the Fireplace

1. Place the fireplace into position.
2. Level the fireplace from side to side and from front to back.
3. Shim the fireplace with non-combustible material, such as sheet metal, as necessary.
4. Secure the fireplace to the framing by nailing or screwing.

The diagram below shows how to properly position, level, and secure the fireplace.

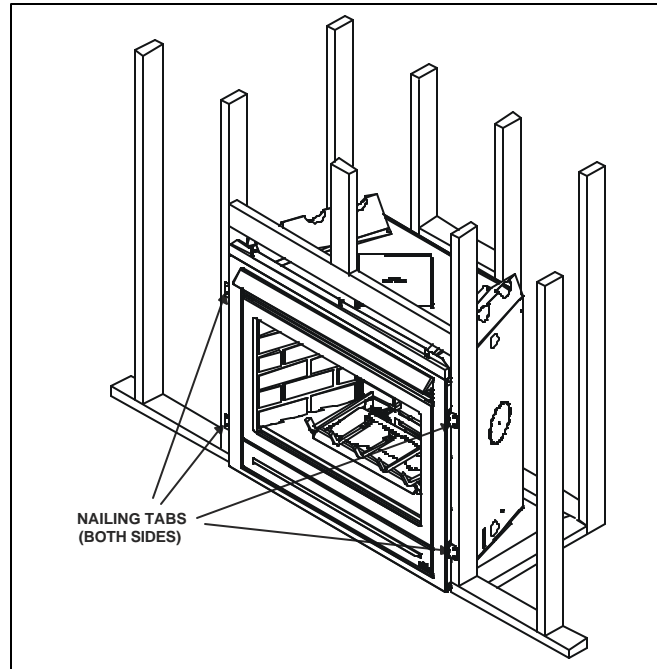

Figure 26. Proper Positioning, Leveling, and Securing of a Fireplace

Step 5 The Gas Control System



WARNING: THIS UNIT IS NOT FOR USE WITH SOLID FUEL.

Standing Pilot Ignition System

This system includes millivolt control valve, standing pilot, thermopile/thermocouple flame sensor, and piezo ignitor.



WARNING: 230 VAC MUST NEVER BE CONNECTED TO A CONTROL VALVE IN A MILLIVOLT SYSTEM.

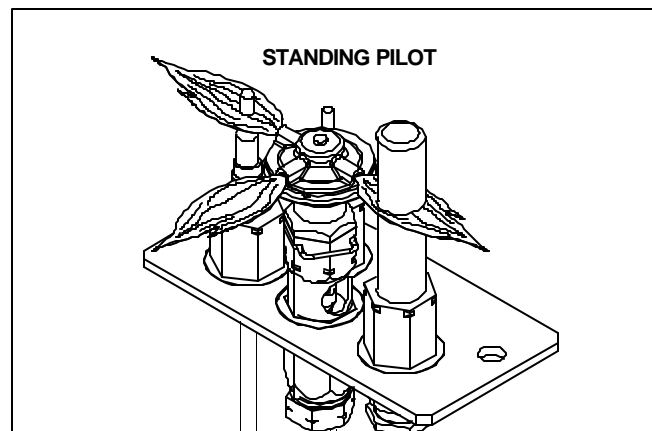

Figure 27. Gas Control System

Step 6 The Gas Supply Line

NOTE: Have the gas supply line installed by a qualified service technician in accordance with all building regulations.

NOTE: Before the first firing of the fireplace, the gas supply line should be purged of any trapped air.

NOTE: Consult local building regulations to properly size the gas supply line leading to the (Rp 1/2") hook-up at the unit.

This gas inlet connection is ISO 7-Rp 1/2 (BSP Rp 1/2).

To install the gas supply line:

- When attaching the pipe, support the control so that the lines are not bent or torn.
- After the gas line installation is complete, use a soap solution to carefully check all gas connections for leaks.



WARNING:
**DO NOT USE AN OPEN FLAME TO
CHECK FOR GAS LEAKS.**

- At the gas line access hole, use insulation to repack the space around the gas pipe.
- Insert insulation from the outside of the fireplace and pack the insulation tightly to totally seal between the pipe and the outer casing.

The gas line should be installed by a qualified service technician.

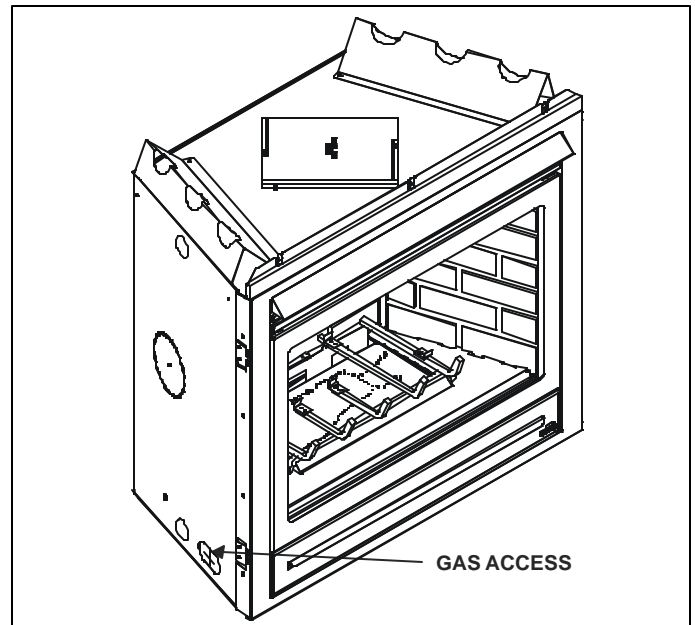

Figure 28

Step 7 Gas Pressure Requirements

Pressure requirements for Heat-N-Glo gas fireplaces are shown in the table below.

	Natural Gas (G20)	Propane (G31)	Butane (G30)	Natural Gas (G25)
Inlet Pressure	20mbar	37 or 50mbar	30 or 50mbar	25mbar
Manifold Pressure	4-8.7mbar	15.7-25mbar	15.7-25mbar	4-8.7mbar
Gas Rate	.54 m ³ /h	.24 m ³ /h	.16 m ³ /h	.54 m ³ /h
◆ Max.Input(NETCV)	10.0 kW	10.0 kW	9.5 kW	8.5 kW
Burner Injector	DMS 33	1.8 mm	DMS 51	DMS 33
Pilot Injector	51	30	30	51

A tap is provided on the outlet side of the gas control for a test gauge connection to measure the manifold pressure. To measure inlet pressure, provisions must be made to attach a test gauge to the tap immediately upstream of the gas supply connection to the fireplace.

The fireplace and its individual shut-off valve must be disconnected from the gas supply piping system during any pressure testing of the system at test pressures in excess of 60 mbar.

If the fireplace must be isolated from the gas supply piping system by closing an individual shut-off valve, it must be of the handle-less type.

Step 8 Wiring the Fireplace

NOTE: Electrical wiring must be installed by a competent electrician.

**For Standing Pilot Ignition Wiring
Appliance Requirements**

Optional Accessories

Optional remote control kits require that 230 VAC be wired to the factory installed junction box before the fireplace is permanently installed.



WARNING: DO NOT CONNECT 230 VAC TO THE GAS CONTROL VALVE OR THE APPLIANCE WILL MALFUNCTION AND THE VALVE WILL BE DESTROYED.

Wall Switch

Position the wall switch in the desired position on a wall. Run a maximum of 780cm or less length of 0.102 cm diameter minimum wire and connect it to the fireplace ON/OFF switch pigtailed.



WARNING: DO NOT CONNECT 230 VAC TO THE WALL SWITCH OR THE CONTROL VALVE WILL BE DESTROYED.

CAUTION

LABEL ALL WIRES PRIOR TO DISCONNECTION WHEN SERVICING CONTROLS. WIRING ERRORS CAN CAUSE IMPROPER AND DANGEROUS OPERATION. VERIFY PROPER OPERATION AFTER SERVICING.

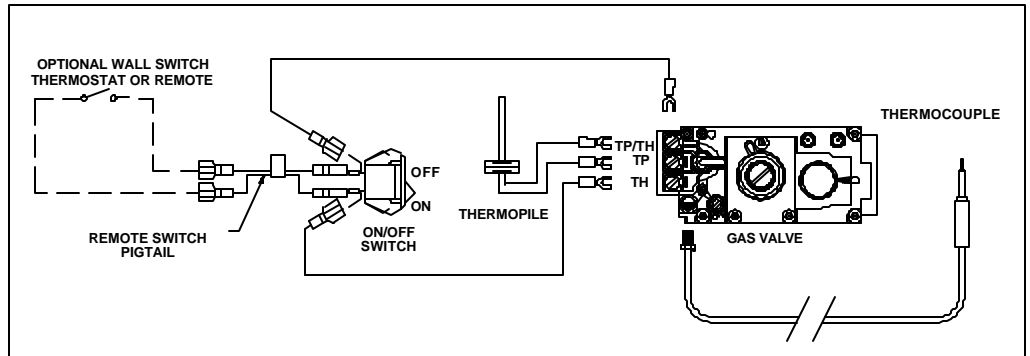

Figure 29. Standing Pilot Ignition Wiring Diagram

**Step 9
Finishing**

The following diagram shows the minimum vertical and corresponding maximum horizontal dimensions of fireplace mantels or other combustible projections above the top front edge of the fireplace. See Figures 2, 3 and 4 for other fireplace clearances.

Only non-combustible materials may be used to cover the black fireplace front.

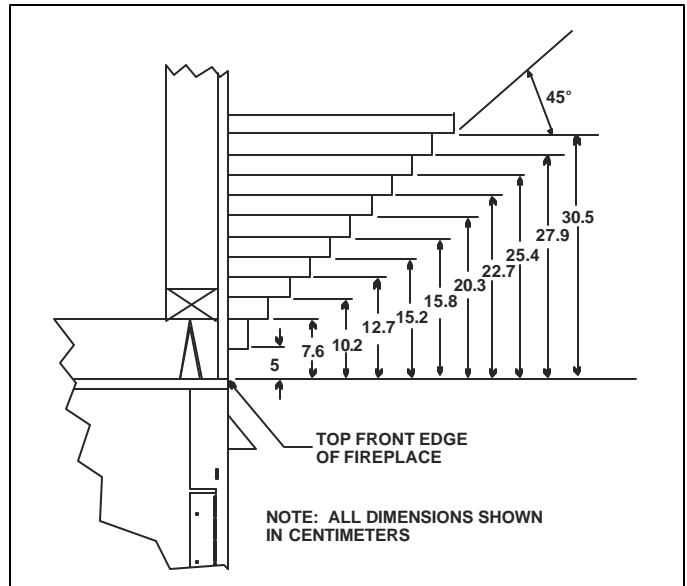

Figure 30. Minimum Vertical and Maximum Horizontal Dimensions of Combustibles above Fireplace



WARNING: WHEN FINISHING THE FIREPLACE, NEVER OBSTRUCT OR MODIFY THE AIR INLET/OUTLET GRILLES IN ANY MANNER.

CAUTION

IF JOINTS BETWEEN THE FINISHED WALLS AND THE FIREPLACE SURROUND (TOP AND SIDES) ARE SEALED, A 150° C. MINIMUM SEALANT MATERIAL MUST BE USED. THESE JOINTS ARE NOT REQUIRED TO BE SEALED. ONLY NONCOMBUSTIBLE MATERIAL (USING 150° C. MINIMUM ADHESIVE, IF NEEDED) CAN BE APPLIED AS FACING TO THE FIREPLACE SURROUND. SEE FIGURE 31.

1. Apply only non-combustible facing material to the fireplace surround.

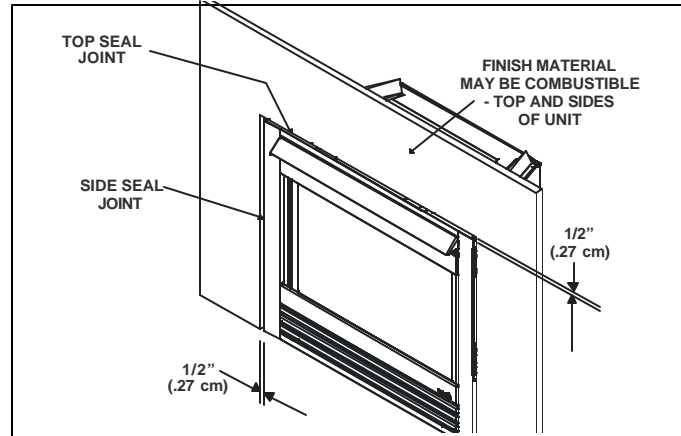

Figure 31. Sealant Material

Step 10 Installing Trim, Refractory, Logs, and Ember Material

Installing the Trim

Combustible materials may be brought up to the specified clearances on the side and top front edges of the fireplace, but **MUST NEVER** overlap onto the front face. The joints between the finished wall, fireplace top and sides can only be sealed with a 150° C minimum sealant.

Install optional marble and brass trim surround kits as desired. Marble, brass, brick, tile, or other noncombustible materials can be used to cover up the gap between the sheet rock and the fireplace.

Do not obstruct or modify the air inlet/outlet grilles. When overlapping on both sides, leave enough space so that the bottom grille can be opened and the trim door removed.



WARNING: CHILDREN AND ADULTS SHOULD BE ALERTED TO THE HAZARDS OF HIGH TEMPERATURES OF WORKING SURFACES ON THESE HEATERS. WORKING SURFACES INCLUDE ALL GLASS PANELS AND DECORATIVE DOORS. YOUNG CHILDREN SHOULD BE CAREFULLY SUPERVISED WHEN THEY ARE IN THE SAME ROOMS AS THE APPLIANCE.

Installing the Ceramic Refractory

Remove dress guard, glass door and log package. Remove refractory pieces from packaging (see Figure 32). Position rear refractory piece first and then slide both side pieces through the upper guide openings until they sit firmly against the rear of the unit. See following pages for log installation instruction.

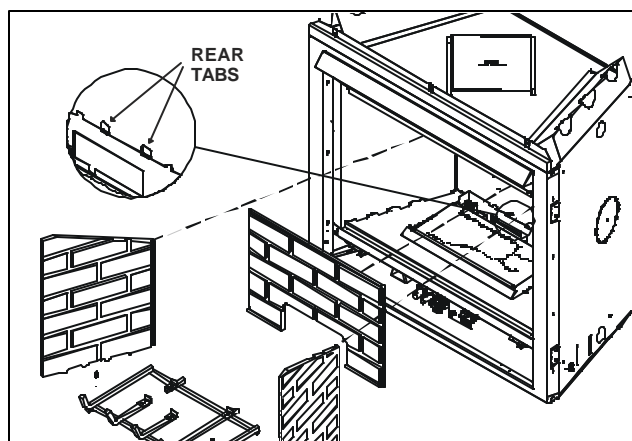
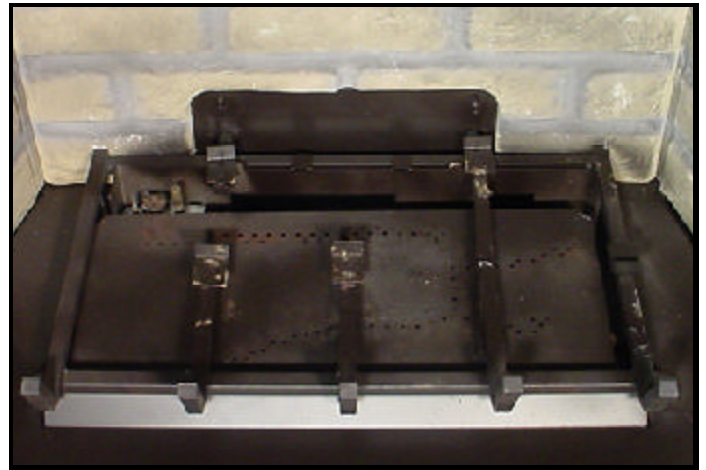

Figure 32. Holding Tabs

Log Set Assembly: LOGS-6TRSCE

LOG PLACEMENT INSTRUCTIONS



Carefully remove the logs from the packaging. **CAUTION:** Logs are fragile!

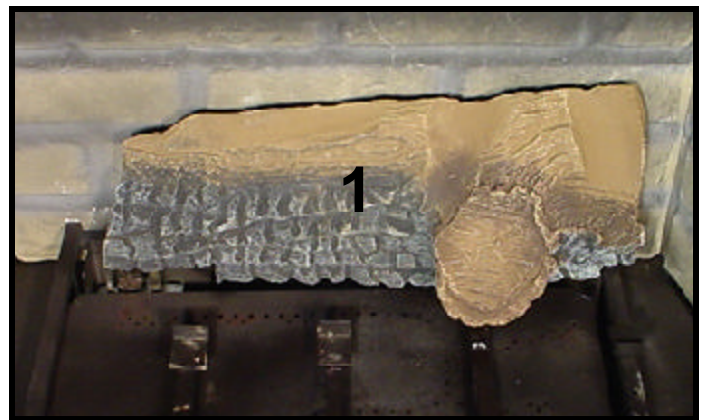
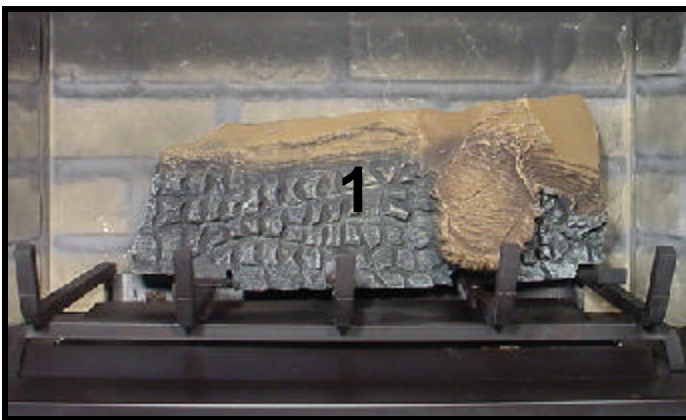

LOG #1 (SRV2049-700): Place log #1 at the rear of the unit against the rear grate tabs with the notches on the bottom of the log lining up with the grate bars.

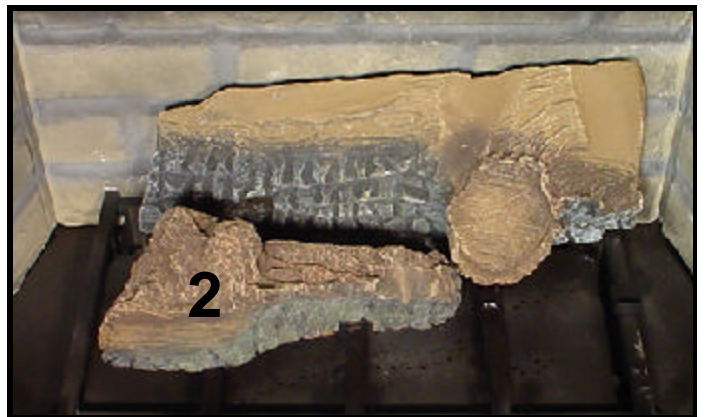
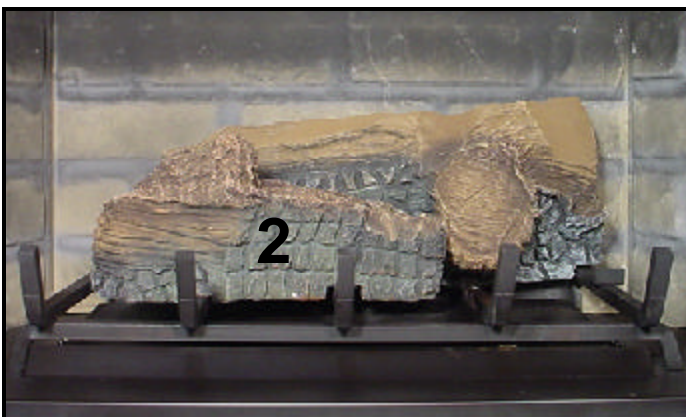

LOG #2 (SRV2049-701): Locate the bottom grooves of log #2 over the second and third grate bars. Push back against the grate tabs on these bars.

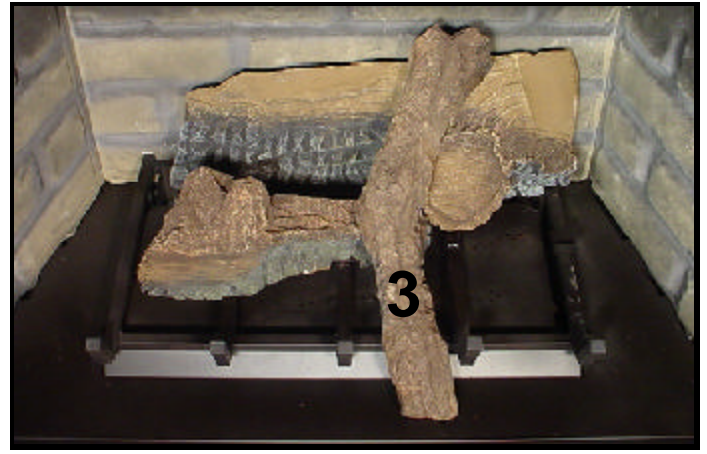
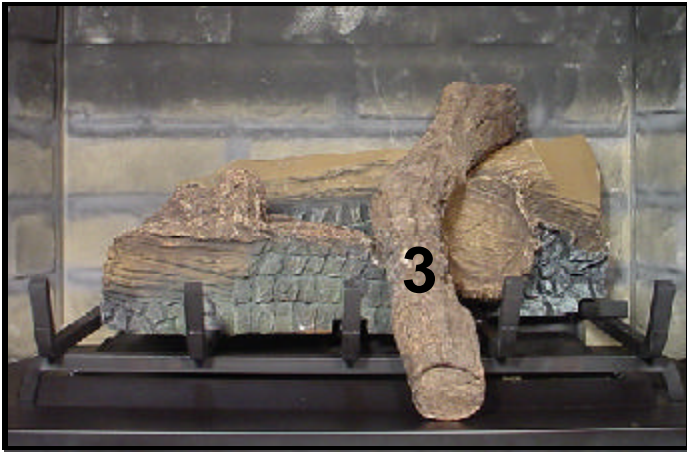

LOG #3 (SRV385-723): Rest log #3 on the grooves on log #1 and log #2.

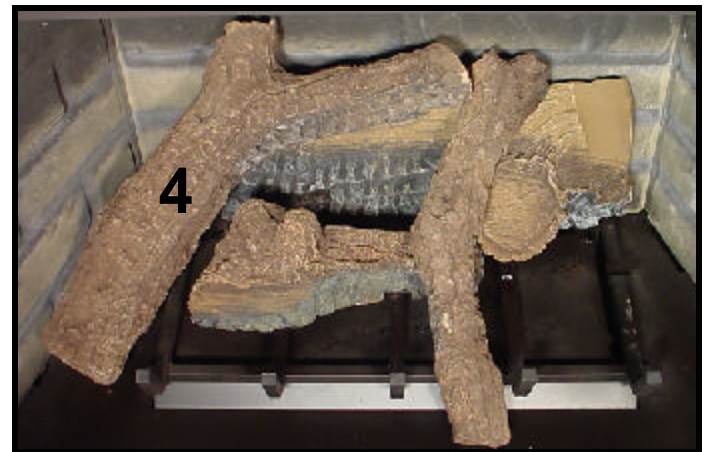

LOG #4 (SRV385-721): Rest log #4 in the groove on log #1 with its front next to the left side of the log grate as shown.



LOG #5 (SRV385-722): Push log #5 against the grate tabs on the 5th grate bar and rest its top in the groove on log #1.

If sooting occurs, the logs might need to be repositioned slightly to avoid excessive flame impingement.

Placing the Ember Material

Two bags of ember material are shipped with this gas fireplace. Use **only a portion** of each bag for the best appearance and operation.

To place the ember material:

- Remove latches and tension springs around the glass door.
- Remove the glass door from the unit (Figure 33).

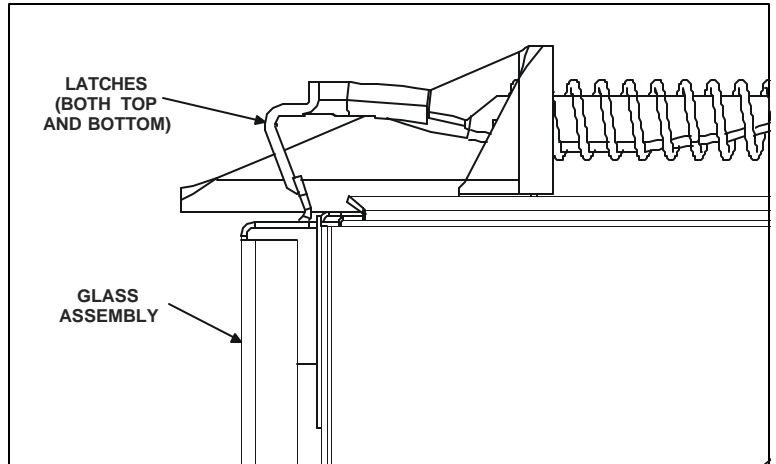

Figure 33. Glass Assembly

- Place small pieces of ember material on burner top (Figure 34). Do NOT press embers into burner ports. Cover the top of the burner with a single layer of ember material. Do NOT place embers on the ports as noted in Figure 34.

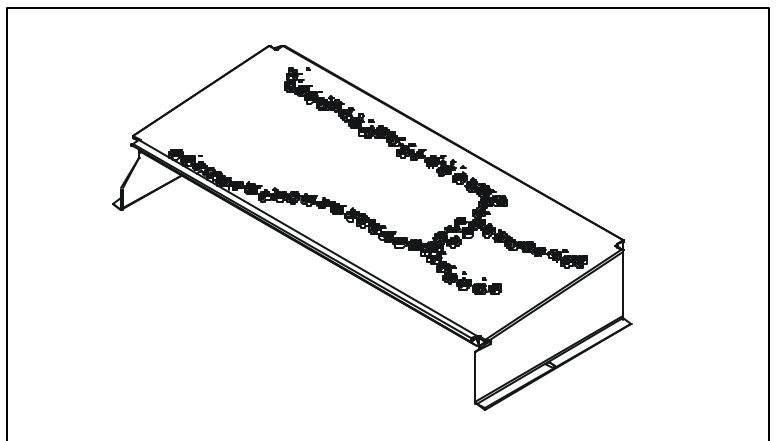

Figure 34. Placement of the Ember Material

- Save the remaining ember materials for use during fireplace servicing.
- Replace the glass door and a front trim door on the unit (see Replacement Parts Section of the manual.)
- Replace the latches and tension springs.

Step 11 Before Lighting the Fireplace

Before lighting the fireplace, be sure to do the following:

Review safety warnings and cautions

- Read the **Safety and Warning Information** section at the beginning of this *Installers Guide*.

Double-check for gas leaks

- Before lighting the fireplace, double-check the unit for possible gas leaks.

Double-check flue terminations and front grilles for obstructions.

- Before lighting the fireplace, double-check the unit for possible obstructions that could be blocking the flue terminations or the front grilles.

Double-check for faulty components

- Any component that is found to be faulty **MUST BE** replaced with an approved component. Tampering with the fireplace components is **DANGEROUS** and voids all warranties.

A small amount of air will be in the gas supply lines. When first lighting the fireplace, it will take a few minutes for the lines to purge themselves of this air. Once the purging is complete, the fireplace will light and will operate normally.

Subsequent lightings of the fireplace will not require this purging of air from the gas supply lines, **unless the gas valve has been turned to the OFF position**, in which case the air would have to be purged.

NOTE: The fireplace should be run for 3 to 4 hours on the initial start-up. Turn it off and let it cool completely. Remove and clean the glass. Replace the glass and run the fireplace for an additional 8 hours. This will help to cure the products used in the paint and logs.

You've reviewed all safety warnings, you've checked the fireplace for gas leaks, you know the flue system is unobstructed, and you've checked for faulty components. Now you're ready to light the fireplace.



WARNING:
**PLEASE REFER TO THE USER'S
MANUAL FOR ALL CAUTIONS, SAFETY,
AND WARNING INFORMATION
PERTAINING TO THE LIGHTING AND
OPERATION OF THE FIREPLACE.**

Step 12 Lighting the Fireplace

After the Installation

**LEAVE THIS INSTALLATION MANUAL
WITH THE APPLIANCE FOR FUTURE
REFERENCE.**

4

Maintaining and Servicing Your Fireplace

Fireplace Maintenance

Although the frequency of your appliance servicing and maintenance will depend on use and the type of installation, you should have a qualified service technician perform an appliance checkup at the beginning of each heating season. See the table below for specific guidelines regarding each fireplace maintenance task.

IMPORTANT

TURN OFF THE GAS BEFORE SERVICING YOUR FIREPLACE.

Type of Fireplace Maintenance	Frequency	By	Fireplace Maintenance Task To Be Completed
Replacing Old Ember Material	Once annually, during the annual checkup	Qualified Service Technician	Brush away loose ember material near the burner. Replace old ember material with new 1 cm thin pieces Glowing Ember (050-721). New ember material should be placed on top of the burner. Save the remaining ember material and repeat this procedure at your next servicing. For more information, see Placing Ember Material in the INSTALLERS GUIDE .
Cleaning Burner & Controls	Once annually	Qualified Service Technician	Brush or vacuum the control compartment, and burner areas surrounding the logs.
Checking Flame Patterns, Flame Height	Periodically	Qualified Service Technician/ Owner	Make a visual check of your fireplace's flame patterns. Make sure the flames are steady — not lifting or floating. See the picture in Figure 35. The thermopile/thermocouple tips should be covered with flame. See the picture in Figure 36.
Checking Flue System	Before initial use and at least annually thereafter, more frequently if possible	Qualified Service Technician/ Owner	Inspect the external terminal cap on a regular basis to ensure that no debris is interfering with the flow of air. Inspect entire flue system for proper function.
Cleaning Glass Door	After the first 3-4 hours of use. As necessary after initial cleaning.	Qualified Service Technician	Remove and clean glass after the first 3 to 4 hours of use. After the initial cleaning, clean as necessary, particularly after adding new ember material. Film deposits on the inside of the glass door should be cleaned off using a household glass cleaner. NOTE: DO NOT handle or attempt to clean the door when it is hot and DO NOT use abrasive cleaners.

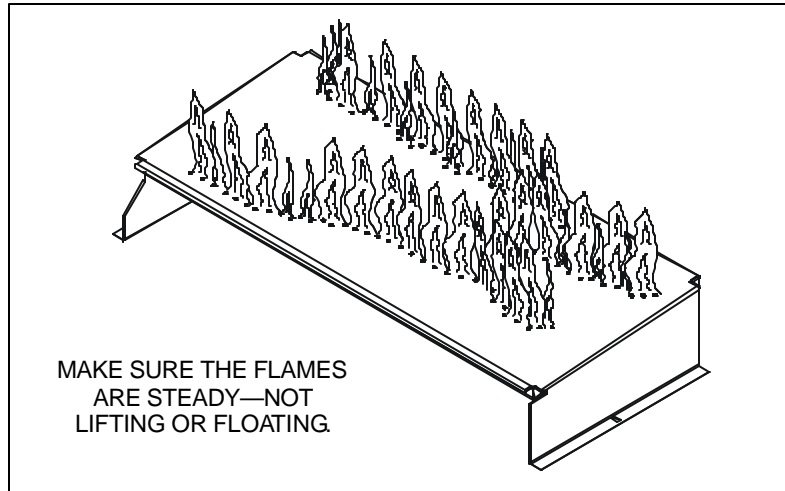

Figure 35. Burner Flame Patterns

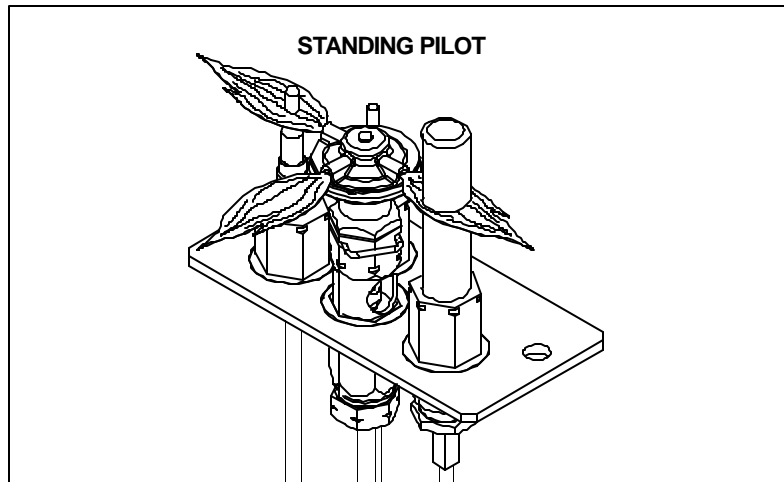

Figure 36. Pilot Flame Patterns

5

Troubleshooting

With proper installation, operation, and maintenance your gas fireplace will provide years of trouble-free service. If you do experience a problem, this troubleshooting guide will assist a qualified service person in the diagnosis of a problem and the corrective action to be taken. This troubleshooting guide can only be used by a qualified service technician.

Standing Pilot Troubleshooting

Symptom	Possible Cause	Corrective Action
1. After repeated triggering of the red or black piezo button, the spark ignitor will not light the pilot.	<p>a. Defective ignitor</p> <p>b. Defective pilot or misaligned electrode (spark at electrode)</p> <p>c. No gas or low gas pressure</p> <p>d. No LP in the tank</p>	<p>Check the spark at the electrode and pilot. If no spark and electrode wire is properly connected, replace the ignitor.</p> <p>Using a match, light the pilot. If the pilot lights, turn off the pilot and trigger the red or black piezo button again. If the pilot lights, an improper gas/air mixture caused the bad lighting and a longer purge period is recommended. If the pilot will not light, ensure that the gap at the electrode and pilot is 0.3 cm to have a strong spark. If the gap is OK, replace the pilot.</p> <p>Check the remote shut-off valves from the fireplace. Usually, there is a valve near the gas main. There can be more than one (1) valve between the fireplace and the main.</p> <p>Check the LP (propane) tank. You may be out of fuel.</p>
2. The pilot will not stay lit after carefully following the lighting instructions.	<p>a. Defective thermocouple</p> <p>b. Defective valve</p>	<p>Check that the pilot flame impinges on the thermocouple. Clean and/or adjust the pilot for maximum flame impingement.</p> <p>Ensure that the thermocouple connection at the gas valve is fully inserted and tight (hand tighten plus 1/4 turn).</p> <p>Disconnect the thermocouple from the valve, place one millivolt meter lead wire on the tip of the thermocouple and the other meter lead wire on the thermocouple copper lead. Start the pilot and hold the valve knob in. If the millivolt reading is less than 15mV, replace the thermocouple.</p> <p>If thermocouple is producing more than 15 millivolts, replace faulty valve.</p>
3. The pilot is burning, there is no gas burner, the valve knob is in the ON position, and the ON/OFF switch is in the ON position.	<p>a. ON/OFF switch or wires defective</p> <p>b. Thermopile may not be generating sufficient millivoltage</p>	<p>Check the ON/OFF switch and wires for proper connections. Place the jumper wires across the terminals at the switch. If the burner comes on, replace the defective switch. If the switch is OK, place the jumper wires across the switch wires at the gas valve. If the burner comes on, the wires are faulty or connections are bad.</p> <p>If the pilot flame is not close enough physically to the thermopile, adjust the pilot flame.</p> <p>Be sure the wire connections from the thermopile at the gas valve terminals are tight and that the thermopile is fully inserted into the pilot bracket.</p>

Symptom	Possible Cause	Corrective Action
3. (Continued)	<p>c. Defective valve</p> <p>d. Plugged burner orifice</p> <p>e. Wall switch or wires are defective</p>	<p>Check the thermopile with a millivolt meter. Take the reading at TH-TP&TP terminals of the gas valve. The meter should read 325 millivolts minimum, while holding the valve knob depressed in the pilot position, with the pilot lit, and the ON/OFF switch in the OFF position. Replace the faulty thermopile if the reading is below the specified minimum.</p> <p>With the pilot in the ON position, disconnect the thermopile leads from the valve. Take a reading at the thermopile leads. The reading should be 325 millivolts minimum. Replace the thermopile if the reading is below the minimum.</p> <p>Turn the valve knob to the ON position. Place the ON/OFF switch in the ON position. Check the millivolt meter at the thermopile terminals. The millivolt meter should read greater than 125mV. If the reading is acceptable, and if the burner does not come on, replace the gas valve.</p> <p>Check the burner orifice for stoppage. Remove stoppage.</p> <p>Follow the corrective action in Symptom and Possible Cause 1. a. above. Check the switch and wiring. Replace where defective.</p>
4. Frequent pilot outage problem.	<p>a. Pilot flame may be too high or too low, or blowing (high), causing pilot safety to drop out</p>	<p>Clean and adjust the pilot flame for maximum flame impingement on thermocouple. Follow lighting instructions carefully.</p>

Symptom	Possible Cause	Corrective Action
5. The pilot and main burner extinguish while in operation.	<ul style="list-style-type: none"> a. No LP in the tank b. Inner flue pipe leaking exhaust gases back into the system c. Horizontal flue improperly pitched d. Glass too loose and air tight packet leaks in corners after usage e. Bad thermopile or thermocouple f. Improper flue cap installation 	<p>Check the LP (propane) tank. Refill the fuel tank.</p> <p>Check for gas leaks.</p> <p>The horizontal flue cap should slope down only enough to prevent any water from entering the unit. The maximum downward slope is 0.6 cm.</p> <p>Tighten the corner.</p> <p>Replace if necessary.</p> <p>Check for proper installation and freedom from debris or blockage.</p>
6. Glass soots.	<ul style="list-style-type: none"> a. Flame impingement b. Improper venturi setting c. Debris around venturi 	<p>Adjust the log set so that the flame does not excessively impinge on it.</p> <p>Adjust the air shutter at the base of the burner.</p> <p>Inspect the opening at the base of the burner. NO MATERIAL SHOULD BE PLACED IN THIS OPENING.</p>
7. Flame burns blue and lifts off burner.	<ul style="list-style-type: none"> a. Insufficient oxygen being supplied 	<p>Ensure that the flue cap is installed properly and free of debris. Ensure that the flue system joints are tight and have no leaks.</p> <p>Ensure that no debris has been placed in the area at the base of, or in the area of, the air holes in the center of the base pan beneath the burner.</p> <p>Ensure that the glass is tightened properly on the unit, particularly on top corners.</p>