

SAREGO



BEDIENUNGSANLEITUNG & GARANTIEKARTE
MODE D'EMPLOI & CARTE DE GARANTIE
ISTRUZIONI OPERATIVE & CARTOLINA DI GARANZIA
INSTRUCTIONS FOR USE & WARRANTY CARD
BEDIENINGSHANDLEIDING & GARANTIEBEWIJS

hase 

D	BEDIENUNGSANLEITUNG	S.	5 - 17
	Garantiekarte im Anhang		
F	MODE D'EMPLOI	P.	19 - 31
	Carte de garantie jointe en annexe		
I	ISTRUZIONI OPERATIVE	PAG.	33 - 45
	Scheda di garanzia in allegato		
GB	INSTRUCTIONS FOR USE	P.	47 - 59
	Warranty card in the appendix		
NL	BEDIENINGSHANDLEIDING	P.	61 - 73
	Garantiebewijs zie bijlage		

Dear Customer,

You have decided to buy a Hase tiled stove.

Traditional craftsmanship, elegant design and the latest combustion technology guarantee you years of enjoyment in front of your SAREGO stove.

The bodywork of the Hase stove comprises strong modern welded steel plates.

The stability and long service life of all Hase models is ensured by both the heat-resistant tiling of the fire box and the temperature-stable special lacquer.

The top quality of all the materials is a matter of course for us as is the greatest possible care we take in production.

All control elements are easily located and simple to use.

Please read through these operating instructions carefully. They will give you helpful hints and useful tips to increase the pleasure you get from your stove.

We hope that you will enjoy many happy hours around your new Hase stove.

**Your
Hase-Kaminofenbau GmbH**

1. INSTALLATION	P.	3. CONTROL AND OPERATING ELEMENTS	P.
1.1 Legal building regulations	48	3.1 Primary and secondary air	53
1.2 Type of construction	48	3.2 The shaking grate	53
1.3 Flue pipe	48	3.3 The ash drawer	53
1.4 Heat-sensitive materials	48	3.4 The throttle flap	53
2. OPERATION	P.	4. HEATING WITH THE SAREGO	P.
2.1 Fuels	49	4.1 Initial operation	54
2.2 The combustion process	49	4.2 Heating with wood	54
2.3 The combustion products	50	4.3 Heating with brown coal briquettes	55
2.4 Your contribution to protecting the environment	50	4.4 Heating with wood at lowest thermal output	56
2.5 Heating between seasons	50	4.5 Heating with briquettes at lowest thermal output	56
2.6 Wood moisture content and calorific value	51		47
2.7 Drying and storing wood	51	5. SAFETY	P.
2.8 Assessment of the wood moisture content	51	5.1 Safe distances	57
2.9 Cleaning and care	52	5.2 Radiation zone	57
		6. HINTS AND TIPS	58
		7. TECHNICAL DATA	59

1.1 Legal building regulations

Before installing your tiled stove we recommend that you talk to your local planning officer. He will advise you on the relevant building regulations, supply permission.

Also check whether the room in which the SAREGO stove is to be installed has an adequate supply of fresh air. If the windows and doors are sealed it may be that the required supply of fresh air is no longer ensured and the draught levels required by your stove may be insufficient. The performance of your tiled stove is also dependent on the draught from your chimney. This may be impaired by the cross section of your chimney or an effective chimney height of less than 4.50 m. The effective chimney height is the distance between the flue gas intake in the chimney and the top of the chimney pot.

1.2 Type of construction

The SAREGO may only be operated with the fire box door being closed. It can be connected to any chimneys already assigned. For reasons of safety, the stove is equipped with a self-closing fire box door.

1.3 The flue pipe

The SAREGO must be connected to a flue pipe whose internal diameter is 150 mm. All the parts must be fitted extremely accurately at the connection points. The pipe must be sealed well in the chimney entrance and must not project into the cavity of the chimney otherwise smoke extraction will be impaired.

1.4 Heat-sensitive materials

If the floor is flammable, for example, if made of wood, plastic or is carpeted, etc., a floor plate must be used. (Please also read Chapter 5: Safety).

2.1 Fuels

In accordance with the First Ordinance on the Implementation of the Federal Emission Reduction Law, only fuels which generate low quantities of smoke may be used in stoves. For Hase stoves these are exclusively:

- natural wood with bark, eg. in the form of logs or bricks, and also brown coal briquettes, Anthracite, & Homefire smokeless fuel.

The following should. NOT BE BURNED:

- painted or plastic-coated wood
- wood treated with wood preservatives
- domestic waste
- paper briquettes (pollutants: cadmium, lead, zinc)
- damp wood (residual moisture content over 20%)
- Bituminous Coal

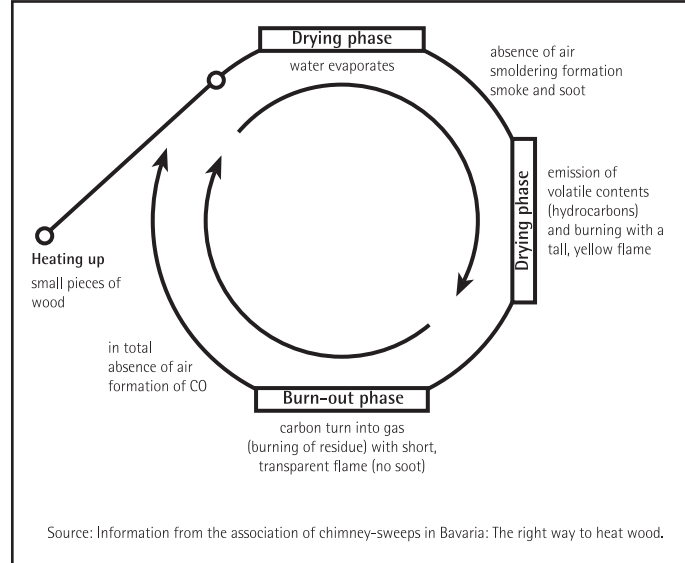

The combustion process

If the above materials are burned they not only generate unpleasant smells but also emissions which damage the environment and are harmful to the health.

Highly resinous kinds of wood (e.g. spruce, pine, fir) tend to give off large quantities of sparks. These types of wood should only be burned with the doors closed. Twigs and sticks of wood

should only be used for lighting the fire.

2.2 The combustion process

The following conditions must be met for burning solid fuels:

- The necessary supply of oxygen must be available. This is generally taken from the ambient air.
- The ignition temperature must be achieved. This means the temperature at which the fuel continues to burn without interruption whilst giving off large quantities of heat.

Steel expands very slightly on heating and contracts again to the same degree on cooling. The steel of which your stove is made also reacts to fluctuations in temperature. Your stove is however designed in such a way as to allow the fire box to expand and contract without damaging the stove. During the firing process the internal action in the steel produces a crackling noise.

Wood combustion can be broken down into three phases:

1. Drying phase

The moisture still contained in the air-dried wood (approx. 15 - 20%) is evaporated. This is done at temperatures of approx. 100°C. The wood must be provided with heat during the warming phase for this purpose, which can be achieved by quick-burning wood.

2. Degasification phase

At temperatures of between 100°C and 150°C the contents of the wood start (slowly at first) to decompose and gasify and the wood begins its thermal decomposition. At temperatures over 150°C the gas development increases strongly.

The proportion of volatile components makes up around 80% of the wood substance. The actual combustion begins with the ignition of the resulting gases at a temperature of around 225°C (ignition temperature) with the emission of heat. There must be an adequate supply of oxygen available for this purpose. The peak of the combustion process is reached at a temperature of around 300°C. The reaction is now so turbulent that the largest amount of heat is released at this point. Flame temperatures of up to 1100°C are possible.

3. Burn-off phase

Glowing charred wood remains after the volatile components have been burned off. This wood burns slowly and almost without flames at a temperature of approx. 800°C.

These processes do not only take place consecutively in a wood fire, however, but also simultaneously. The combustion process is shown in the schematic diagram (s. Figure).

2.3 The combustion products

From a chemical point of view wood mainly consists of the elements carbon, hydrogen and oxygen.

Wood contains almost no substances which are critical from an environmental point of view, such as sulphur, chloride and heavy metals. Therefore after the total combustion of wood the main gaseous products are carbon dioxide and water vapour as well as a small quantity of wood ash which is the solid combustion product.

If the wood does not combust fully on the other hand, a series of pollutant substances may be emitted, such as carbon monoxide (toxic), acetic acid, phenols, methanol (toxic), formaldehyde, soot and tar.

2.4 Your contribution to protecting the environment

Whether your stove burns in a manner that is harmful to the environment or not depends to a large extent on how you operate it and the type of fuel you use (see Section 2.1).

The following hints are intended to help you with this:

- Use only dry wood, leaf-wood like birch and beech are most suitable. (see Sections 2.6 and 2.7).
- Only use small pieces of wood to light the fire. These will burn more easily than large logs and the temperature required for total combustion of the wood will be reached more quickly.
- Do not place too much wood in the stove at one time. It is better to add smaller quantities more frequently. The quantity of wood must always be adjusted to the amount of heat required.

The quality of the combustion process can be checked very easily by means of the following features:

- *The colour and characteristics of the ash.* If the combustion process

is good the result will be fine white ash. Dark colouration indicates that the ash contains charcoal residue.

The burn-off phase in this case has been incomplete.

- *The colour of the flue gases emitted from the chimney.* In this respect remember the following: the less colour in the flue gases emitted from the chimney, the better the quality of the combustion process.

2.5 Heating between seasons

Between seasons (in spring and autumn) you may experience draught difficulties in the chimney if the outdoor temperature is over 16°C. If no draught can be created at these temperatures by a quick fire (temporary generation of great heat by rapidly burning paper or thin wood Chipping's) you should not light the stove.

2.6 Wood moisture content and calorific value

The calorific value of the wood depends largely on the wood moisture content. The more water the wood contains, the more energy must be used to evaporate it. This energy is then lost for heating. The more moisture the wood contains, therefore, the less its calorific value. An example: freshly cut wood has a moisture content of approx. 50% and a calorific value of around 2.3 kWh/kg; wood which has been well dried in the air, on the other hand, has a moisture content of approx. 15% and a calorific value of around 4.3 kWh/kg.

Therefore, if you use very moist wood you will have around half the heat output with the same quantity of wood than when you use dried wood. To be also considered is the fact that if you burn moist wood, the resulting water vapour can condense in the flue pipe or chimney. This can lead to pitting or the chimney becoming sooted or tarred up. Furthermore, if the wood has a high moisture content the combustion temperature is reduced which prevents total combustion of all the wood components and causes considerable pollution. The energy content of

the unburned wood is also lost. It is quiet clear, therefore, that burning inadequately dried wood is irresponsible both from an economical and an ecological point of view.

2.7 Drying and storing wood

As explained under Section 2.6 low wood moisture content is of great importance. Therefore, the following provides a few tips on how to dry and store wood.

- Wood needs time to dry. It will dry in the air outdoors after approx. one to two years if stored properly.
- The wood should be stored ready for use after being sawn and split. This ensures rapid drying because smaller pieces of wood will dry better than logs several metres in length.
- Your logs should be stored in a ventilated, if possible sunny position and be protected from rain (ideally facing south).
- Leave a hand's width between the individual piles of wood so that air can get in between them and remove any escaping moisture.
- Do not cover the piles of wood with

plastic sheets or tarpaulins because the moisture will then be unable to escape.

- Do not stack fresh wood in a cellar since it will rot rather than dry for the lack of air movement.
- Only store dried wood in dry cellar rooms.

2.8 Assessment of the wood moisture content

For you as a stove user it is important to be able to assess whether your wood is air dry (with a residual moisture content less than 20%) or whether it must be stored for a longer period.

The air-dried condition has been reached when the moisture content of the wood is in balance with the ambient air, i.e. it no longer dissipates moisture to the air and no longer takes moisture out of the air. The weight of the wood is characteristic for the moisture balance.

One method which allows you to assess the moisture content is described here. You must observe the points listed under Point 2.7 as a basis for optimum wood storage. Then proceed as follows:

- Take a log from various points in your wood pile.
- Mark these logs to enable you to identify them easily.
- Now weigh the logs on a kitchen scale and make a note of their weights.
- Now dry the logs artificially for several hours (e.g. in a warm stream of convection air from the stove).

- Then place the logs back in the wood pile where they were.
- Weigh the logs again one or two days later.

The moisture balance will be disturbed by drying the logs. The logs will therefore try to reproduce the balance after being dried by taking moisture out of the air. If they achieve the same weight as when they were first weighed they have absorbed the same quantity of water which they lost through being dried. This means that the moisture had balanced out before the wood was weighed for the first time.

If, on the other hand, they are still lighter, there was more water in them before they were weighed for the first time than required for the moisture balance. Therefore, these logs have to be stored for a while longer.

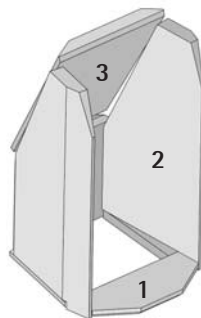

fig. 1



fig. 2

2.9 Cleaning and Maintenance

The chimney stove and the smoke tubes should be inspected each year - if required, even more often - at the end of the heating period for deposits. To clean the flue pipes remove the heat-resisting slabs from the combustion chamber in the order shown. Any soot or dust residue can be brushed off and vacuumed. Replace heat-resisting slabs in reverse order. [fig. 1]

We will have to provide the steel stoves with a finish of heat-resistant paint. However, heat-resistant stove lacquers do not provide protection against corrosion, with the result that a rust film may form in unfavourable conditions, for example caused through:

- the use of too much water for cleaning the floor/base plate area.
- spilt water from boilers or dishes.
- the positioning in "moist rooms", e.g. conservatories, or the intermediate storage in the building carcass/garage

Clean areas covered in a rust film with emery paper and spray them with stove lacquer spray (available at your Hase specialist dealer).

From time to time, the handling shaft should be greased (for grease see accessories drawer of your stove).

[fig. 2]

Do not use any detergents containing acid (e.g. citrus or vinegar detergents) to clean the steel parts. Sufficient cleaning can be achieved by wiping the steel parts with a slightly dampened cloth.

When the stove is properly operated, the secondary air simultaneously forms an air curtain in front of the pane and delays the sooting of the glass.

A time-tested environment friendly method for cleaning the ceramic glass panels with materials which are available in every household is as follows:

Take:

- 1 ball of kitchen paper, newspaper, or the like
- wet it
- dip it into the cold wood ash
- wipe the glass with it
- wipe the glass with a clean ball of paper and the job is done.

3.1 Primary and Secondary Air

The Sarego features a primary and secondary air valve.

1. Primary air

The primary air is guided into the combustion chamber from below and is needed for heating up and briquette burning. Except when burning briquettes, the primary air slide must be closed during the burning phase.

CAUTION:

When burning wood with opened primary air slide there is a risk of the stove overheating (forge fire effect).

2. Secondary air

The secondary air is guided into the combustion chamber from the top. It carries the volume of oxygen into the combustion chamber required to completely burn the wood gas and ensures that, if used correctly, the window to the combustion chamber remains free of soot.

To regulate the secondary air, the following general rule applies:

A small fire requires little secondary air; a large fire requires much secondary air. If the secondary air valve is not sufficiently open there is a risk that the windows will soot up.

The operating elements of the valves are to the bottom right of the stove [see fig.].

For settings of operational elements see Chapter 4.

3.2 The shaking grate

The shaking grate serves to dispose of components (ash) which have not been burned and to feed them into the ash safe, to supply combustion air during heating up and during the firing of charcoal briquettes. It is operated via a slide located to the right below the fire box [b]. If brown coal briquettes are fired, the shaking grate must be opened by pulling out the slide.

3.3 The ash drawer

The ash drawer [c] must be emptied in good time. Ash piling up can prevent primary air from getting to the stove.

Please make sure that the ash is only removed when it is cold.

The ash drawer stands in its turned over lid when collecting ash. To empty the drawer pull out the lid, turn it over and push it on the ash drawer. This closes the ash drawer and prevents flying ash. This, in turn, keeps your home clean when you dispose of the ash. The ash drawer is put back into the stove by proceeding in the reverse order.

3.4 The throttle flap

The throttle flap is fitted in the flue pipe and is used to regulate the flue gas flow. It is not fitted in every flue pipe and is also not absolutely essential. The influence of the throttle valve on the burn off is dependent on many factors, including the chimney height and cross section, the indoor and outdoor temperature, etc. When the handle is horizontal the throttle flap is closed.

If the fire box door is opened during the firing process, first of all the throttle valve must have been opened.



4.1 Initial operation

Please observe that during the first 2 to 3 firings a distinct odor will be experienced.

4.2 Heating with wood

Lighting

A fast heating-up phase is important as higher rates of emissions during the heating up and lighting phase may occur if operated incorrectly. For environmental reasons we therefore ask

you to strictly observe the following sequence. The fire should always be lit with wood.

During heating-up the primary air valve and the secondary air valve should be fully opened. The further position of the secondary air slide depends on the draught of the chimney. The slide settings described here are recommendations that apply under standard conditions.

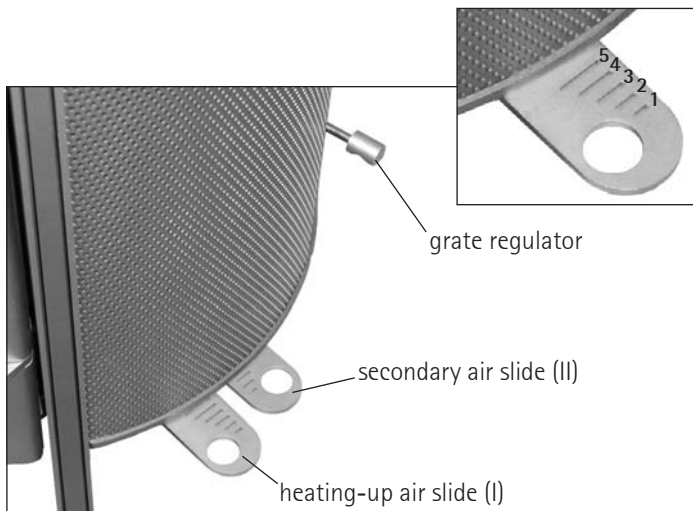

Procedure	Position of control elements
Open the throttle flap entirely, if your flue pipe has one	Set handle of throttle flap along the length of the pipe
Open fire box door	
Open shaking grate	Pull out shaking grate slide
Open heating-up air slide completely	Push heating-up air slide (I) to the right
Open secondary air slide completely	Push secondary air slide (II) to the right
Sweep remaining ash and any unburned charcoal into the centre with broom	
Place screwed up newspaper, non-coated cardboard or wood wool into the middle of the firebox, top it with around 0.5 kg dry wood chippings and around 1.5 kg wood (2 logs)	
Light the material at several points	
Close fire-box door	
Once the wood is sufficiently lit at all sides please close the shaking grate and the primary air slide (I) (after about 2-5 min.)	Fully slide in shaking grate Set primary air slide (I) to position 1
Later bring the secondary air slide (II) to the ideal position (c. 15-20 min.)	Set secondary slide (II) to position 4

Continuous heating/adding wood

After reaching operational temperature and observing certain basic rules heating is feasible at a very low rate of emission of exhaust gas. Heating capacity depends on feeding of fuel. The respective fuel quantities and lengths of logs are:

- nominal capacity 7 kW: 2 logs à 0.8 kg per feed
- minimum heat capacity 3.5 kW: 2 logs à 0.4 kg per feed logs measure 20-25 cm.

These are guidelines to assist you. Use smaller logs during the heating-up phase.

ATTENTION:
When feeding more fuel, the stove may overheat.

<i>Adding wood</i>		Position of control elements
Procedure		
Open the throttle flap entirely, if your flue pipe has one		Set handle of throttle flap along the length of the pipe.
Set control elements		Set heating-up air slide (I) to second groove Set secondary air slide (II) to three-quarters
Slowly open fire box door to prevent smoke from entering the surroundings		
Close shaking grate		Push in shaking grate slide
Place two logs each around 1 kg lengthways Add a single layer of combustible		
Close door for fire box		
<i>Wood should be added when the flames of the prior fire are about to die</i>		

4.3 Heating with brown coal briquettes

Both wood and brown coal briquettes can be used to fire your SAREGO.

<i>Heating with brown coal briquettes</i>		Position of the control elements
Procedure		
Lighting		
Light with wood as previously described		See instructions for lighting
Further heating		
When the first glow has been reached, place four briquettes (2.1 kg) at the centre of the bottom of the fire box above the shaking grate.		
Open shaking grate		Pull out shaking grate slide
Open heating-up air valve		Three-quarters
Set secondary air flow		Set secondary air slide (I) to second groove

4.4 Heating with wood at lowest thermal output

Regulate the heating capacity of your stove with the fuel quantity. Proceed as follows for lower heating requirements:

Procedure	Position of control elements
Close shaking grate	Push shaking grate slide in
Close heating-up air slide	Slide heating-up air slide (I) to the left
Set secondary air	Set secondary air slide (II) at three-quarters
56 Add two logs of wood (around 0.5 kg) lengthways	

4.5 Heating with briquettes at lowest thermal output

Procedure	Position of control elements
Place two briquettes on shaking grate	
Open shaking grate	Pull out shaking grate slide
Set heating-up air	Set heating-up air slide (I) on fourth groove
Set secondary air	Set secondary air slide (II) to second groove

5. Safety

Never use **methylated spirits; petrol or other flammable fluids to light the stove.**

Children should never be left unattended near the burning stove.

5.1 Safe distances

With flammable materials (eg. wood panelling, plastic cladding and curtains) the safe distance to the side and behind the stove is at least 20 cm. Flammable floor materials (eg. carpet, wood or plastic flooring) must be protected to the front and side with a non-flammable covering (eg. tiles, marble or steel plate) (see Fig. 1).

According to DIN 18891 the following safe distances are valid when using a covering for the floor:

A 50,0 cm

B 30,0 cm

Distance of combustibile materials

C 20,0 cm

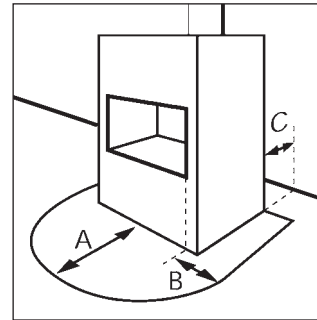

Fig. 1: Dimensions of bottom plate

5.2 Radiation zone

No flammable or heat-sensitive materials are to be left within a distance of 80 cm in the radiation zone (see Fig. 2).

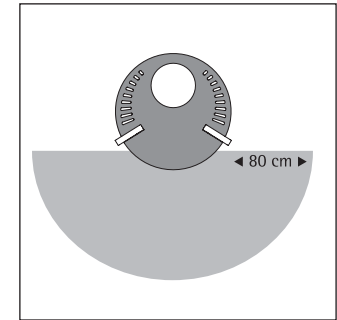

Fig. 2: Radiation zone

Problem	Cause	Remedy
The wood does not light or only does so slowly	The wood is too thick The wood is too damp The air supply is too low	Section 4.2 Continue heating Section 2.8 Section 4.2 Lighting
The wood burns without a bright, yellow flame, smoulders or even goes out	The wood is too damp The air supply is too low The throttle flap is closed too far	Section 2.8 Section 4.2 Lighting Section 3.5
Too much soot is generated, the insulating tiles do not stay clean	The wood is too damp The air supply is too low The quantity of wood is too small and thus the combustion chamber remains too cold	Section 2.8 Section 4.2 Continue heating
Although the fire burns well the stove does not get warm	The chimney draught is too strong	Section 3.4
The wood burns up too quickly	The chimney draught is too strong The wood has been cut too small Incorrect setting of operating elements	Section 3.4 Section 4.2 Section 4.2
Smoke escapes into the room while the stove is burning	The air supply is too low The throttle flap is closed too far The chimney cross section is too small The flue gas ducts in the stove pipe or chimney are badly sooted The wind is blowing down the chimney	Ensure supply of fresh air (i.e. open the window) Section 3.3 Fit a draught booster (flue gas fan) Section 2.9 Fit a wind guard on the chimney pot
The chimney becomes wet and sooty, condensate runs out of the stove pipe	The wood is too damp The flue gases are too cold The chimney is too cold The chimney cross-section is too large	Section 2.8 The stove pipe is too long and must be insulated The chimney must be insulated

Stove **SAREGO**, certified according to **DIN 18891-A2**
VKF-No. 11669

Combustion values:

The following data shall apply to the dimensions of the chimney in accordance with **DIN 4705**:

Nominal thermal output	7	kW
Thermal output min / max	3,5 - 7	kW
Waste gas mass flow rate	8,33	g/s
Waste gas outlet temperature	322	°C
Minimum delivery pressure at nominal thermal output	0,10	mbar

The nominal thermal output of **7 kW** indicated on the unit's type plate will be sufficient for 56 to 144 m³ depending on the isolation of the house (volume in accordance with DIN 18893)

Measures:

	Height	Width	Depth
Oven	111,5 cm	42,7 cm	42,7 cm
Fire box	42 cm	21 cm	30 cm
	Tile	Steel	Soapstone
Weight	-	135 kg	-

Measures for installation:

a	Height for top installation	107,5 cm
c	Height for the installation of a , connection piece for fresh air, centre of the pipe	32,5 cm
d	Measure	11,7 cm

Fire box opening	928 cm ²
Pipe (diameter internal)	150 mm
Combustion air inlet (diameter internal)	100 mm

Connection branch top

Safety distances from flammable materials

