



# Merida

- D** Wartungs- und Montageanleitung
- F** Notice de montage et d'entretien
- I** Istruzioni di montaggio e manutenzione
- GB** Maintenance and Installation Instructions
- NL** Onderhouds- en montagehandleiding

hase 



## D Inhalt

1. Stückliste.....	4
2. Wartungshinweis .....	5
3. Übersicht .....	6
4. Montagen der Justierfüße.....	7
5. Umrüstung des Ofenrohranschlusses von oben nach hinten.....	7
6. Keramikmontage .....	9
7. Hase-Luftsysteem - Anschluss unten .....	12
8. Hase-Luftsysteem - Anschluss hinten .....	12
9. Ausbau der Thermosteine (Einbau in umgekehrter Reihenfolge) .....	13
10. Wechsel der Türdichtung .....	15
11. Nachfetten .....	16
12. Reinigung.....	17

## F Sommaire

1. Liste des pièces .....	4
2. Consigne de maintenance .....	5
3. Vue d'ensemble .....	6
4. Montage des pieds de réglage.....	7
5. Modification du raccordement du conduit de fumée d'en haut vers l'arrière.....	7
6. Montage de la céramique.....	9
7. Système d'air Hase - Raccordement en bas.....	12
8. Système d'air Hase - Raccordement arrière.....	12
9. Démontage des pierres thermiques (montage en sens inverse) .....	13
10. Remplacement du joint de la porte.....	15
11. Regraisser.....	16
12. Nettoyage.....	17

## I Indice

1. Elenco dei componenti .....	4
2. Istruzioni di manutenzione .....	5
3. Panoramica .....	6
4. Montaggio dei piedini di regolazione .....	7
5. Spostamento dell'innesto del canale da fumo dall'alto al retro.....	7
6. Montaggio della maiolica .....	9
7. Sistema di ventilazione Hase - Collegamento in basso .....	12
8. Sistema di ventilazione Hase - Collegamento posteriore.....	12
9. Smontaggio delle pietre termiche (il montaggio si effettua seguendo l'ordine inverso).....	13
10. Sostituzione della guarnizione della sportello.....	15
11. Procedere all'ingrassaggio .....	16
12. Pulizia .....	17

## GB Content

1. Parts list.....	4
2. Service note .....	5
3. Overview .....	6
4. Mounting the levelling feet.....	7
5. Changing the location of the Flue Pipe Connection from top to rear of stove .....	7
6. Ceramic installation.....	9
7. Hase ventilation system - Bottom connection .....	12
8. Hase ventilation system - Rear connection .....	12
9. Dismounting the heat-resisting stones (Reverse the process to mount them).....	13
10. Replacing the door seal.....	15
11. Regrease .....	16
12. Cleaning.....	17

## NL Inhalt

1. Stuklijst.....	4
2. Aanwijzingen voor het onderhoud .....	5
3. Overzicht .....	6
4. Montage van de justervoetjes .....	7
5. Ombouw van de rookbuisaansluiting van boven naar achteren.....	7
6. Montage van de keramische tegels .....	9
7. Hase-ventilatiesysteem - Vloeraansluiting .....	12
8. Hase-ventilatiesysteem - Achteraansluiting.....	12
9. Demonderen van de thermo stenen (montage in omgekeerde volgorde) .....	13
10. Vervangen van de deurichting .....	15
11. Smeren .....	16
12. Reiniging .....	17

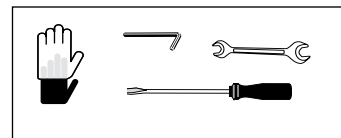

1. **Stückliste / Liste des pièces / Elenco dei componenti / Parts List / Stuklijst**



**S1** 4x

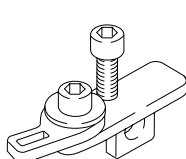

**S2** 5x

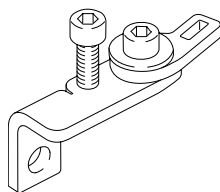

**S3** 5x

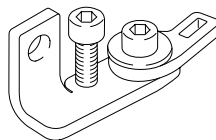

**S4** 4x



**S5** 44x  
Ø 18



**S6** 14x  
M6x5

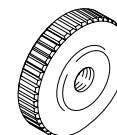

**S7** 14x

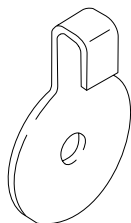

**S8** 14x



**S9** 2x  
Ø 12



**S10** 2x  
M6



**S11** 4x  
M4



**S12** 4x  
M4

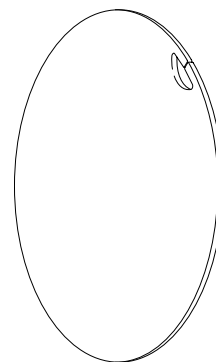

**S20** 1x

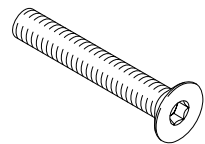

**S13** 5x  
M6x40



**S14** 4x  
M4



**S17** 5x  
M6

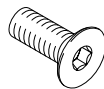

**S18** 2x  
M6x16

**Keramik / Céramique / Maiolica  
Ceramic / Keramiek**

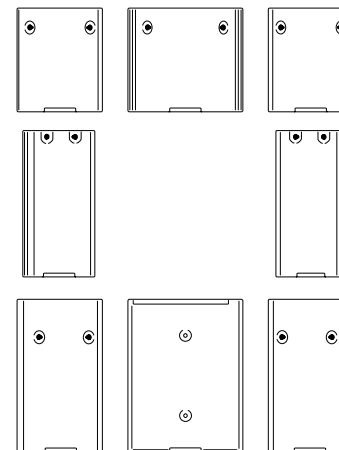

### 3. Wartungshinweis / Consigne de maintenance / Istruzioni di manutenzione / Service note / Aanwijzingen voor het onderhoud

---

- D** Um einen einwandfreien Betrieb Ihres Hase-Kaminofens zu gewährleisten, empfehlen wir jährlich vor Beginn der Heizperiode, folgende Punkte zu überprüfen bzw. durchzuführen:
1. Zustand der Thermosteine. Ersetzen Sie beschädigte oder fehlende Thermosteine wie unter 9. beschrieben.
  2. Zustand der Türdichtung prüfen. Ersetzen Sie schadhafte Dichtungen wie unter 10. beschrieben.
  4. Nachfetten (siehe 11.).
  5. Reinigung des Abgassystems (siehe 12.).
- F** Pour garantir un fonctionnement irréprochable de votre cheminée Hase, nous vous conseillons de contrôler / d'effectuer les points suivants annuellement avant le début de la période de chauffe.
1. État des pierres thermiques. Remplacez les pierres thermiques endommagées ou manquantes comme décrit sous 9.
  2. Contrôlez l'état du joint d'étanchéification de la porte. Remplacez les joints détériorés comme décrit sous 10.
  3. Regraisser (voir 11).
  4. Nettoyage du système d'échappement des gaz (voir 12).
- I** Onde poter garantire un perfetto funzionamento del vostro forno a camino, vi consigliamo di voler osservare annualmente prima del periodo di riscaldamento i seguenti punti di sicurezza:
1. Stato delle pietre termiche Sostituite le pietre termiche difettose o mancanti come descritto al punto 9.
  2. Esaminare lo stato della guarnizione della porta. Sostituite le guarnizioni difettose come descritto al punto 10.
  4. Procedere all'ingrassaggio (vedi 11.).
  3. Pulizia del sistema del gas di scarico (vedi 12.).
- GB** In order that your Hase stove runs efficiently, we recommend that you follow these instructions every year before the heating period begins:
1. Check the condition of the thermo-stones. Replace any damaged or missing thermo-stones, as described in point 9.
  2. Check the condition of the door seals Replace any damaged seals, as described in point 10.
  3. Regrease (see 11.)
  4. Clean the exhaust system (see 12.)
- NL** Om te waarborgen dat uw Hase kachel probleemloos functioneert, raden we u aan om jaarlijks, voor het begin van het stookseizoen, de onderstaande punten te controleren ofwel uit te voeren:
1. De staat van de thermostenen. Het vervangen van beschadigde of ontbrekende thermostenen, zoals beschreven onder 9.
  2. Het testen van de staat van de deurafdichting. Het vervangen van beschadigde dichtingen, zoals beschreven onder 10.
  3. Smeren (zie 11.).
  4. Het reinigen van het afvoersysteem voor het uitlaatgas (zie 12.)

3. Übersicht / Vue d'ensemble / Panoramica / Overview / Overzicht /

---

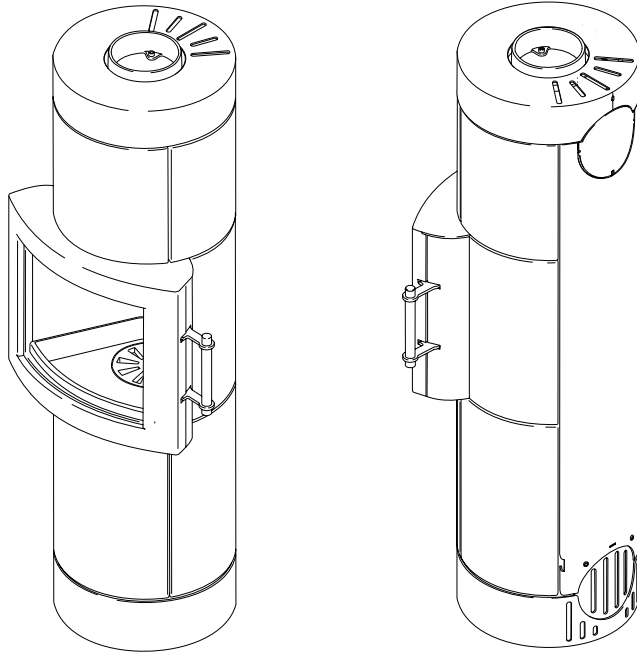

4. Montage der Justierfüße / Montage des pieds de réglage / Montaggio dei piedini di regolazione / Mounting the levelling feet / Montage van de justervoetjes

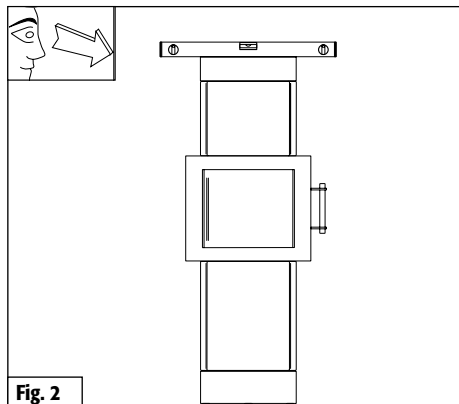
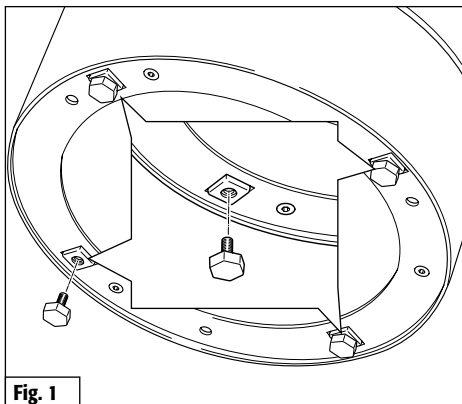

5. Umrüstung des Ofenrohranschlusses von oben nach hinten / Modification du raccordement du conduit de fumée d'en haut vers l'arrière / Spostamento dell'innesto del canale da fumo dall'alto al retro / Changing the Location of the Flue Pipe Connection from Top to Rear of Stove / Ombouw van de rookbuisaansluiting van boven naar achteren

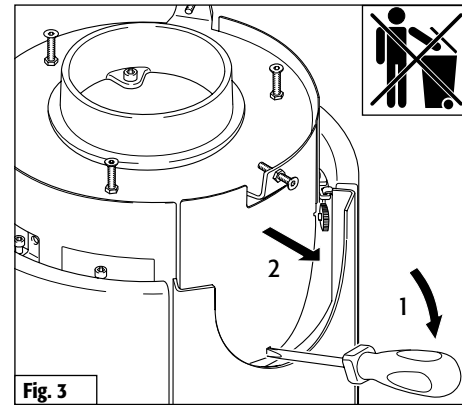
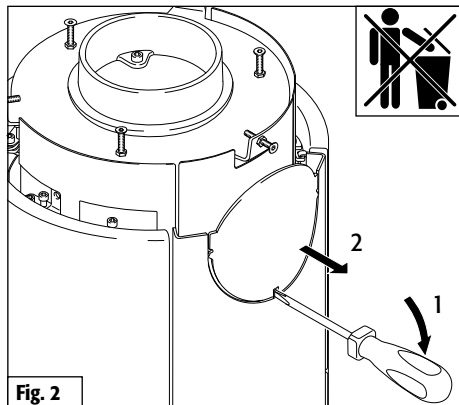
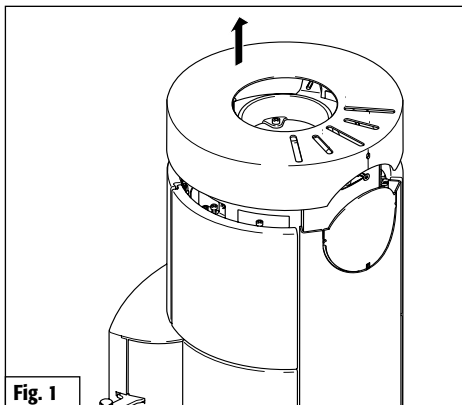

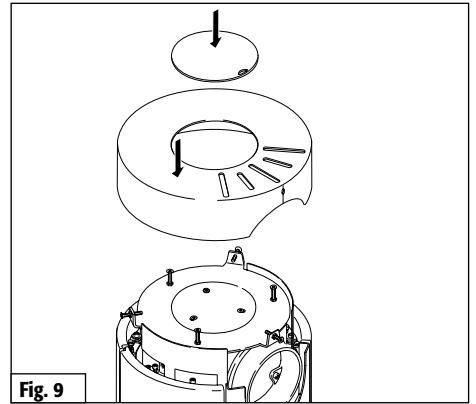
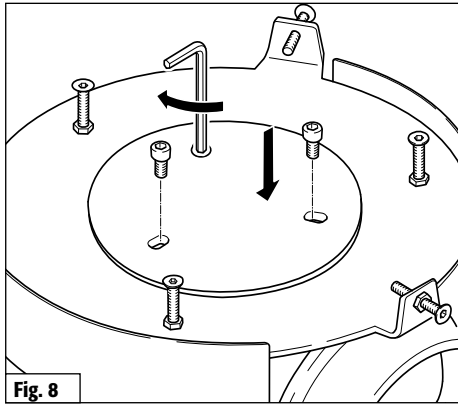
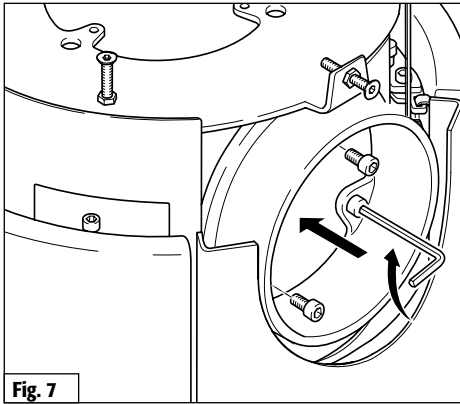
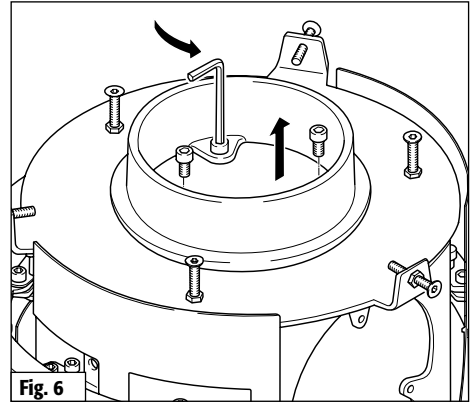
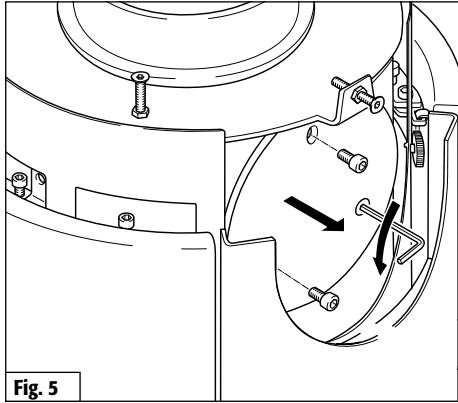
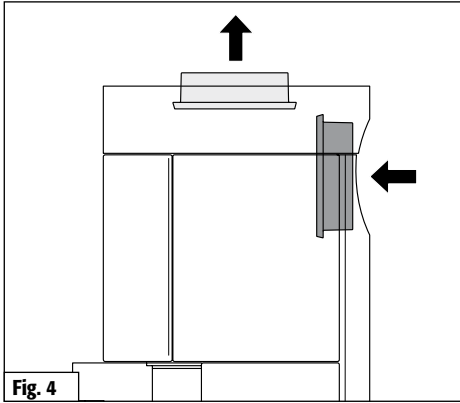

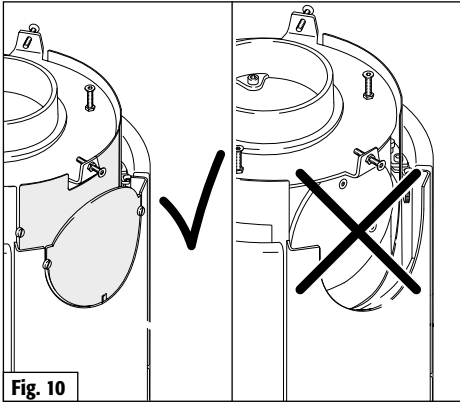

6. **Keramikmontage / Montage de la céramique / Montaggio della maiolica / Ceramic installation / Montage van de keramische tegels**

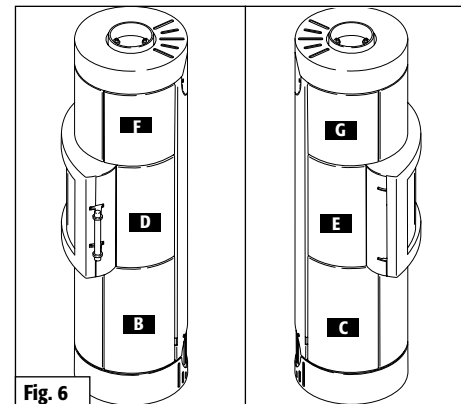
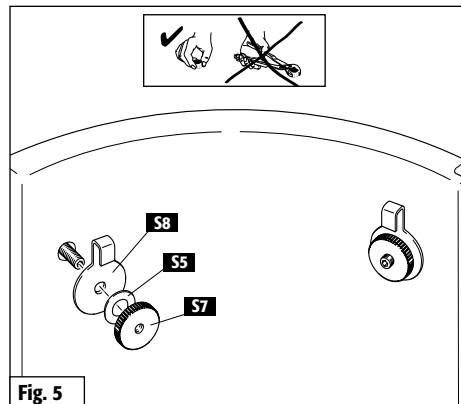
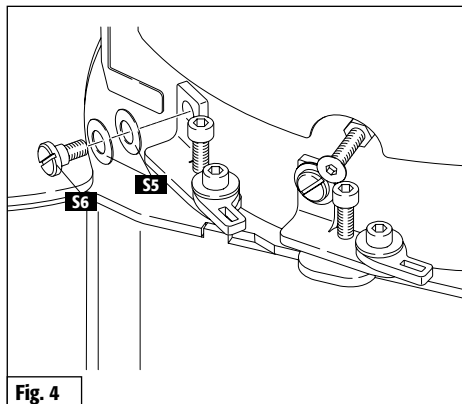
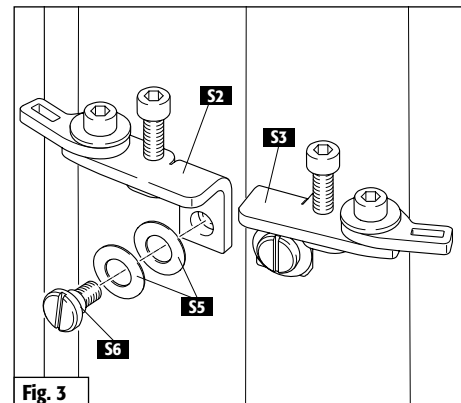
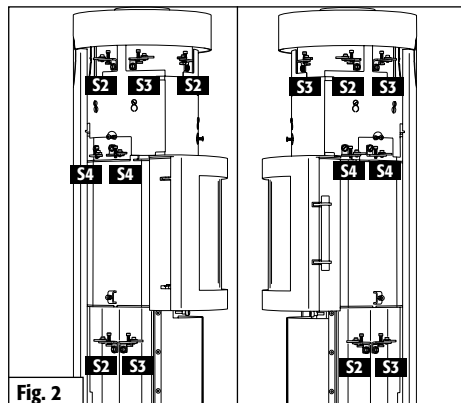
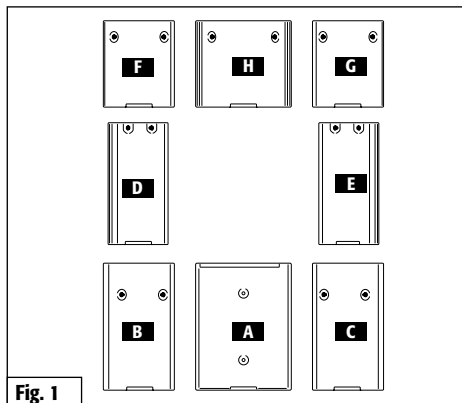

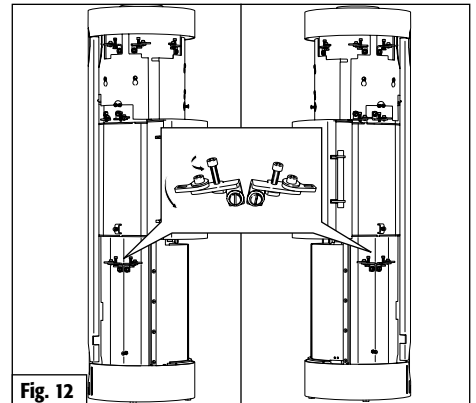
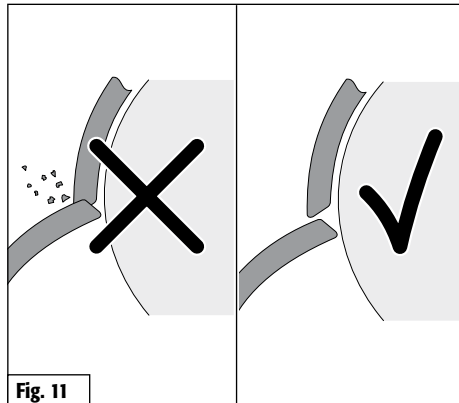
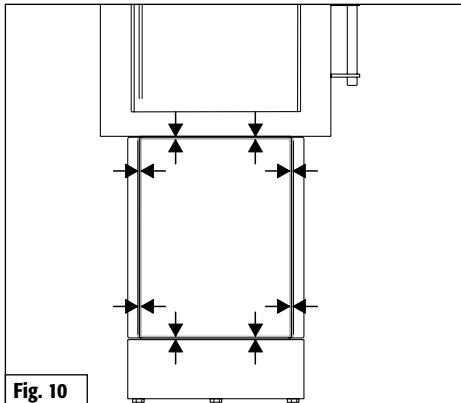
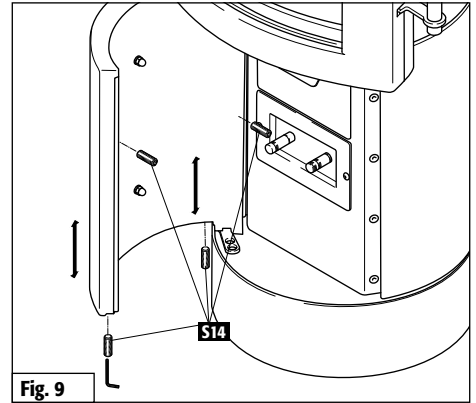
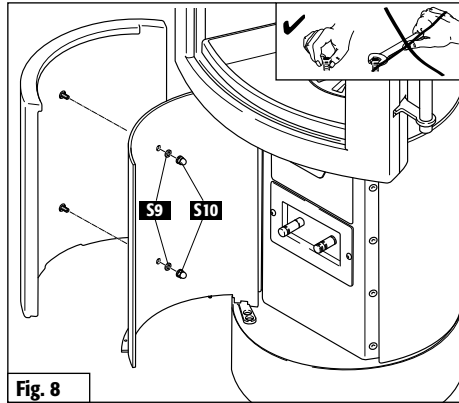
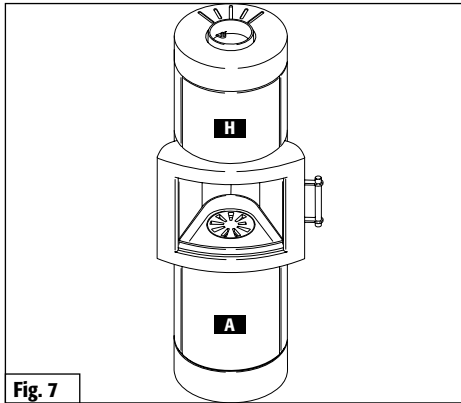

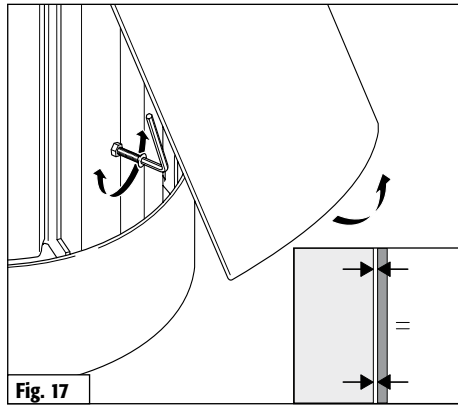
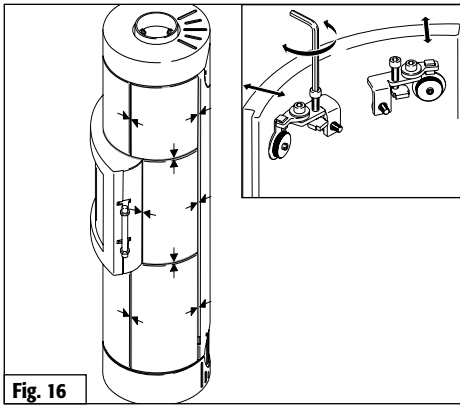
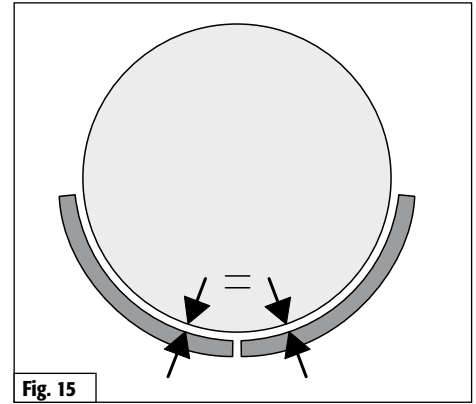
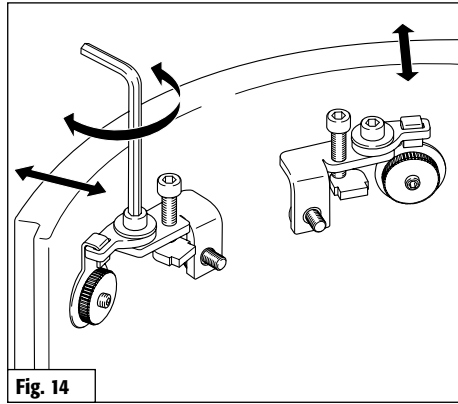
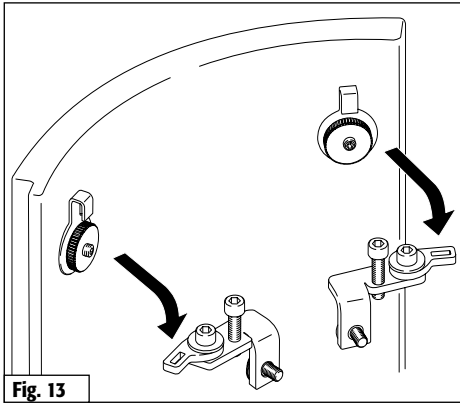

**7. Hase-Luftsystem - Anschluss unten / Système de ventilation Hase - Raccordement en bas / Sistema di ventilazione Hase - Collegamento in basso / Hase ventilation system - Bottom connection / Hase-ventilatiesysteem - Vloeraansluiting**

---

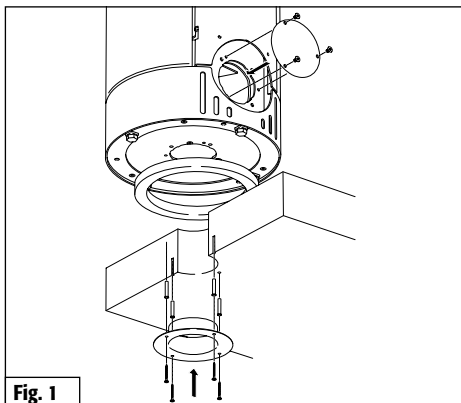

**8. Hase-Luftsystem - Anschluss hinten / Système de ventilation Hase - Raccordement arrière / Sistema di ventilazione Hase - Collegamento posteriore / Hase ventilation system - Rear connection / Hase-ventilatiesysteem - Achteraansluiting**

---

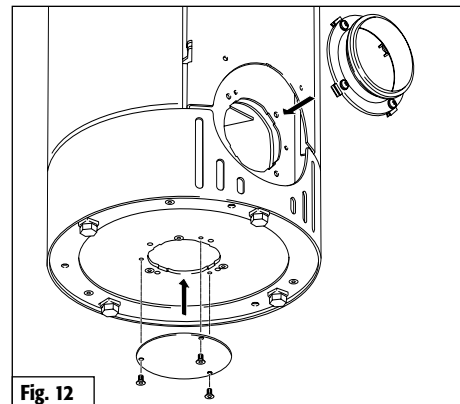
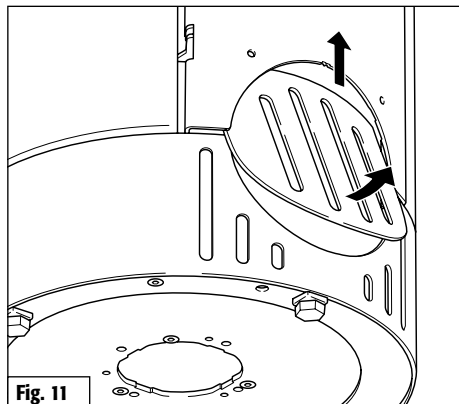
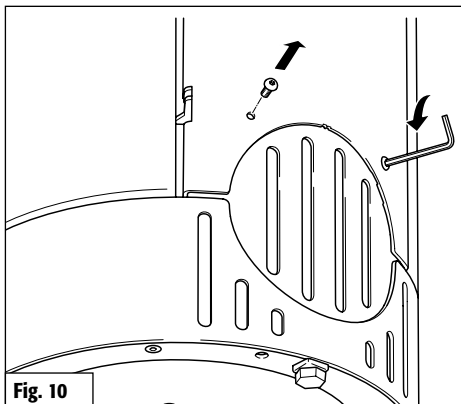

9. Ausbau der Thermosteine (Einbau in umgekehrter Reihenfolge) / Démontage des pierres thermiques (montage en sens inverse) / Smontaggio delle pietre termiche (il montaggio si effettua seguendo l'ordine inverso) / Dismounting the Heat-resisting stones (Reverse the process to mount them) / Demonteren van de thermo stenen (montage in omgekeerde volgorde)

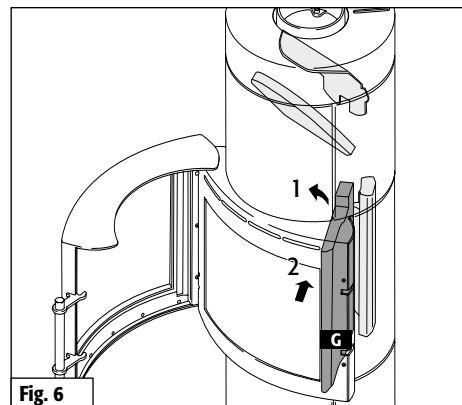
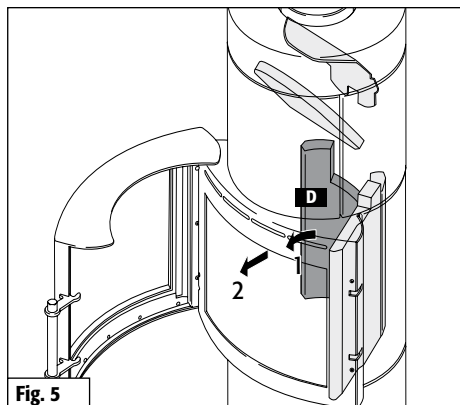
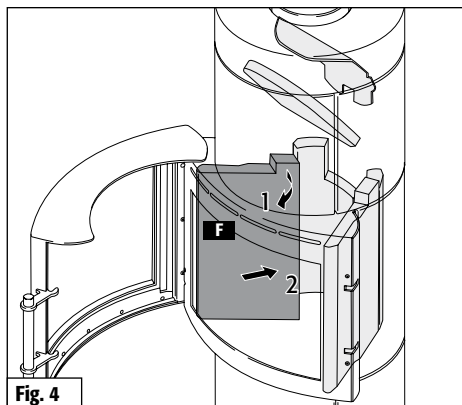
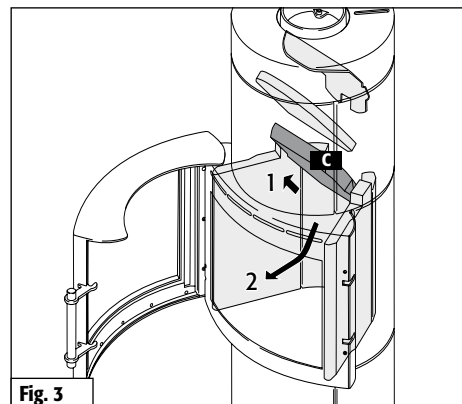
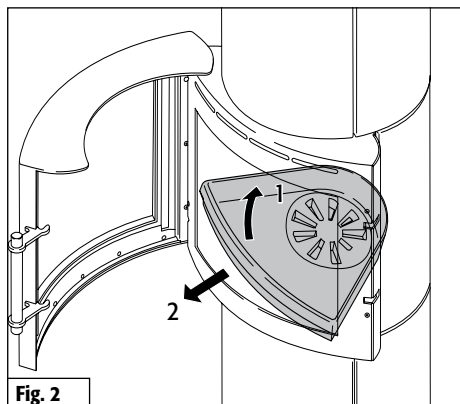
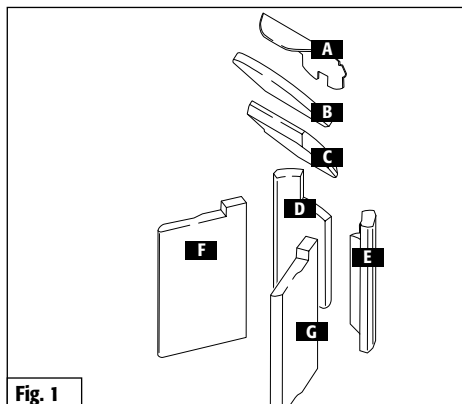

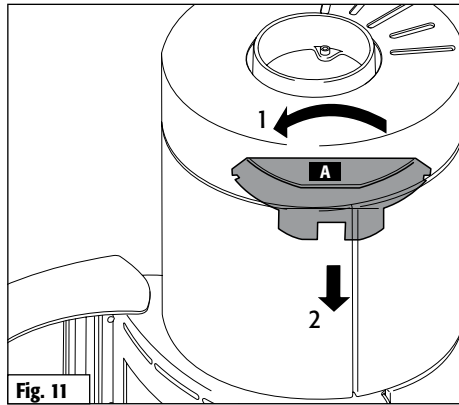
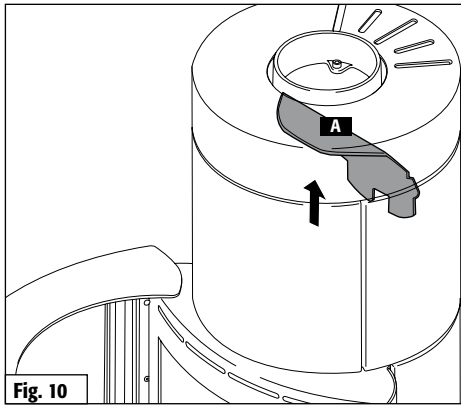
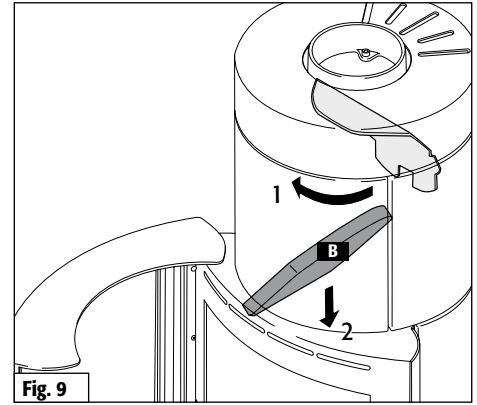
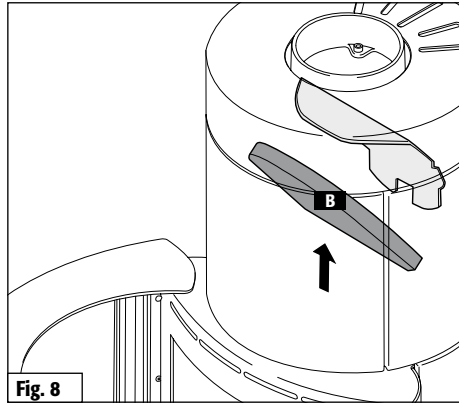
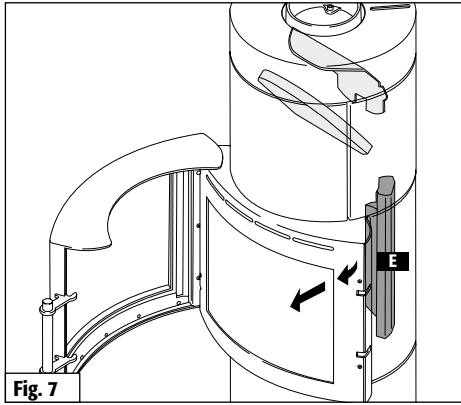

10. Wechsel der Türdichtung / Remplacement du joint de la porte / Sostituzione della guarnizione della sportello / Replacing the Door Seal / Vervangen van de deur dichting

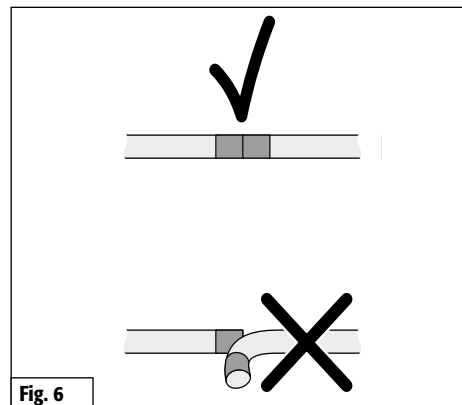
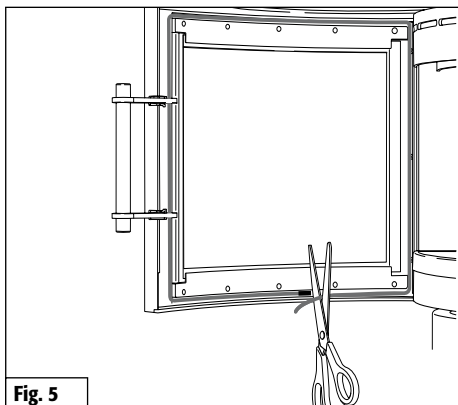
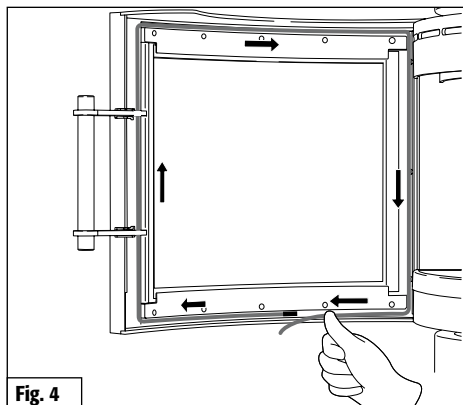
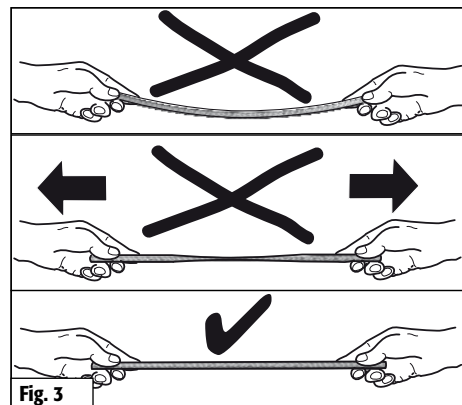
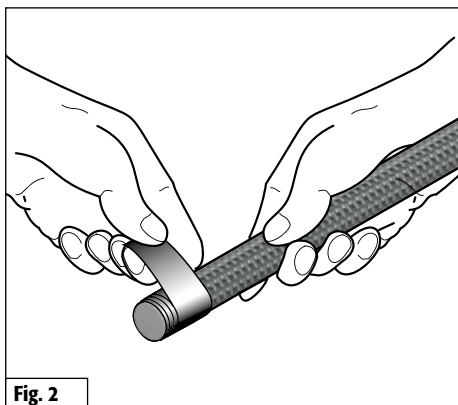
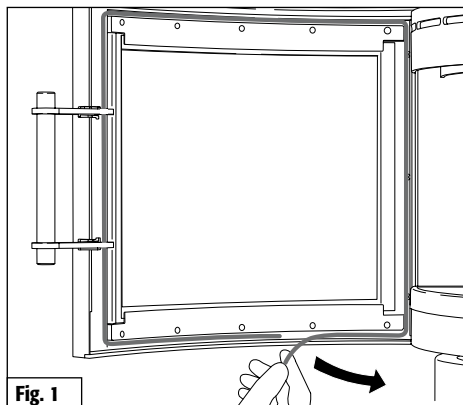

## 11. Nachfetten / Regraisser / Procedere all'ingrassaggio / Regrease / Smeren

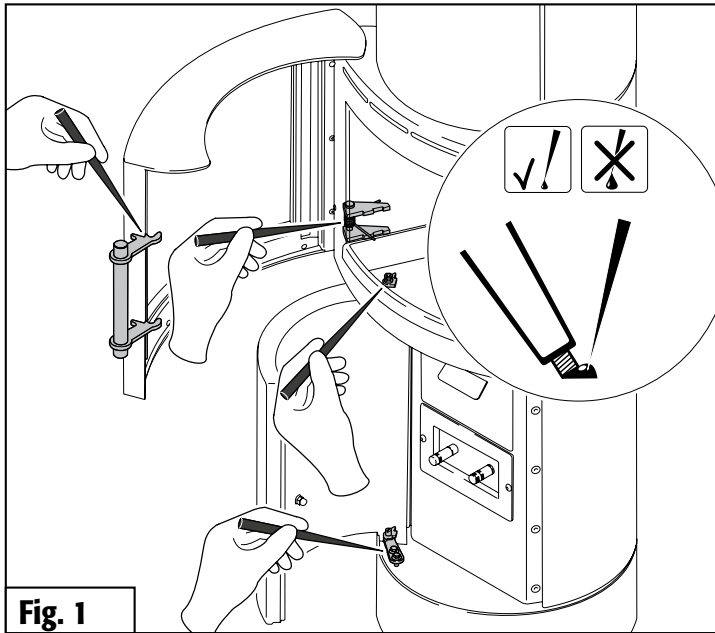
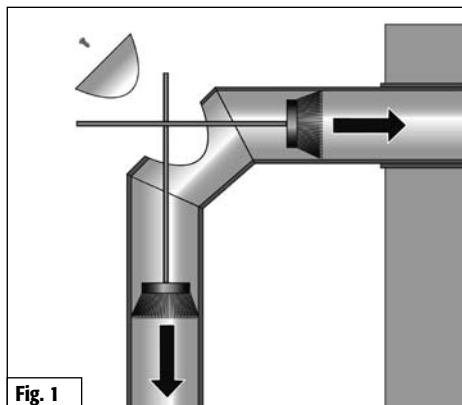

Fig. 1

- ⓓ Fetten Sie bei Bedarf die Türmechanik mit einem hochhitzebeständigen Spezialfett nach. Das Spezialfett ist über Ihren Hase-Fachhändler erhältlich.
- ⓕ Regraissez en cas de besoin le mécanisme de la porte avec une graisse spéciale résistante à la chaleur. La graisse spéciale est disponible chez votre revendeur Hase.
- Ⓡ In caso di necessità, Vi preghiamo di ingrassare la meccanica della porta con un grasso speciale resistente al calore. Questo grasso speciale è acquistabile dal Vostro fornitore specializzato Hase.
- ⓖB If required re-grease the door mechanism using a high-temperature resistant special grease. Special grease is available from your Hase stockist.
- ⓃL Vet indien nodig het deurmechanisme met een zeer hittebestendig speciaalvet in. Het speciaalvet is verkrijgbaar via uw Hase-vakhandel.

## 12. Reinigung / Nettoyage / Pulizia / Cleaning / Reiniging



**! WARNING!**  
**Kaminofen nur im abgekühlten Zustand reinigen, es besteht Verbrennungsgefahr.**

Der Kaminofen und die Rauchrohre sollten mindestens einmal jährlich auf Ablagerung untersucht und bei Bedarf gereinigt werden.

Zur Reinigung öffnen Sie die am Rauchrohr befindlichen Reinigungsöffnungen (Fig. 1) und bürsten vorhandene Ablagerungen nach unten in den Kaminofen und nach hinten in den Kamin. Öffnen Sie den Feuerraum und entnehmen die oberen Bauteile (Abs. 9; A, B und C). Bürsten oder saugen Sie die Ablagerungen ab und setzen anschließend die Bauteile wieder ein.

**! ATTENTION !**  
**Pour nettoyer le poêle-cheminée, attendez qu'il soit froid. Risque de brûlure.**

Vérifier les dépôts dans le poêle-cheminée et les conduits de fumée au moins une fois par an et, le cas échéant, les nettoyer. Pour le nettoyage, ouvrez l'ouverture (fig. 1) prévue à cet effet sur le conduit de fumée et brossez les dépôts vers le bas pour les faire tomber dans le poêle-cheminée et vers l'arrière dans la cheminée. Ouvrez la porte du foyer et enlevez les composants du haut (alinéa 9; A, B, et C). Enlevez les dépôts avec une brosse ou un aspirateur, puis remettez les composants en place.

**! ATTENZIONE!**  
**Pulire la stufa camino solo quando è fredda.**  
**Pericolo di ustioni.**

Controllare la stufa camino ed i canali da fumo almeno una volta l'anno per verificare l'eventuale presenza di depositi ed eventualmente pulirli. Per effettuare la pulizia aprire le aperture per la pulizia poste sul canale da fumo (fig. 1) e con una spazzola eliminare gli eventuali depositi, in basso in direzione della stufa camino e verso dietro in direzione del camino. Aprire il focolare e rimuovere le componenti poste in alto (paragrafo 9; A, B, e C). Eliminare i depositi con una spazzola o con un aspirapolvere. Inserire quindi nuovamente le componenti

**! WARNING!**  
**Only clean the stove when it is completely cool, otherwise there is a danger of getting burnt.**

Check the stove and flue pipes for deposits at least once a year and clean them, if necessary. To clean, open the cleaning ports located on the flue pipe (Fig. 1) and brush away any deposits downward into the stove and backwards into the chimney. Open the fire box and dismount the upper components (Section 9; A, B, and C). Brush off or vacuum up any deposits and then replace the components.

**! OPGELET!**  
**De kachel enkel reinigen wanneer die is afgekoeld, anders bestaat het gevaar dat u zich verbrandt.**

De kachel en de rookbuizen moeten ten minste één keer per jaar worden gecontroleerd op roetvorming. Indien nodig moet men ze reinigen. Om te reinigen de reinigungsopeningen aan de rookbuis openen (fig. 1) en met een borsteltje het roet in de schoorsteen en in de kachel naar beneden en naar achteren verwijderen. Open de stookruimte en neem er de bovenste componenten uit (punt 9; A, B en C). Verwijder het roet met een borsteltje of zuig het weg en monteer daarna opnieuw de componenten.





hase 

Hase Kaminofenbau GmbH · Niederkircher Str. 14 · 54294 Trier · Tel.: (06 51) 82 69-0 · Fax: (06 51) 82 69 118 · info@hase.de · www.hase.eu