



A K A B A raumluftunabhängig

**indépendant de l'air ambiant
con alimentazione aria esterna
direct vent stove
gesloten systeem**

BEDIENUNGSANLEITUNG & GARANTIEKARTE

MODE D'EMPLOI & CARTE DE GARANTIE

ISTRUZIONI OPERATIVE & CARTOLINA DI GARANZIA

INSTRUCTIONS FOR USE & WARRANTY CARD

BEDIENINGSHANDLEIDING & GARANTIEBEWIJS

hase 

D	BEDIENUNGSANLEITUNG	S.	3 - 21
	Garantiekarte im Anhang		
F	MODE D'EMPLOI	P.	23 - 41
	Carte de garantie jointe en annexe		
I	ISTRUZIONI OPERATIVE	PAG.	43 - 61
	Scheda di garanzia in allegato		
GB	INSTRUCTIONS FOR USE	P.	63 - 81
	Warranty card in the appendix		
NL	BEDIENINGSHANDLEIDING	P.	83 - 101
	Garantiebewijs zie bijlage		

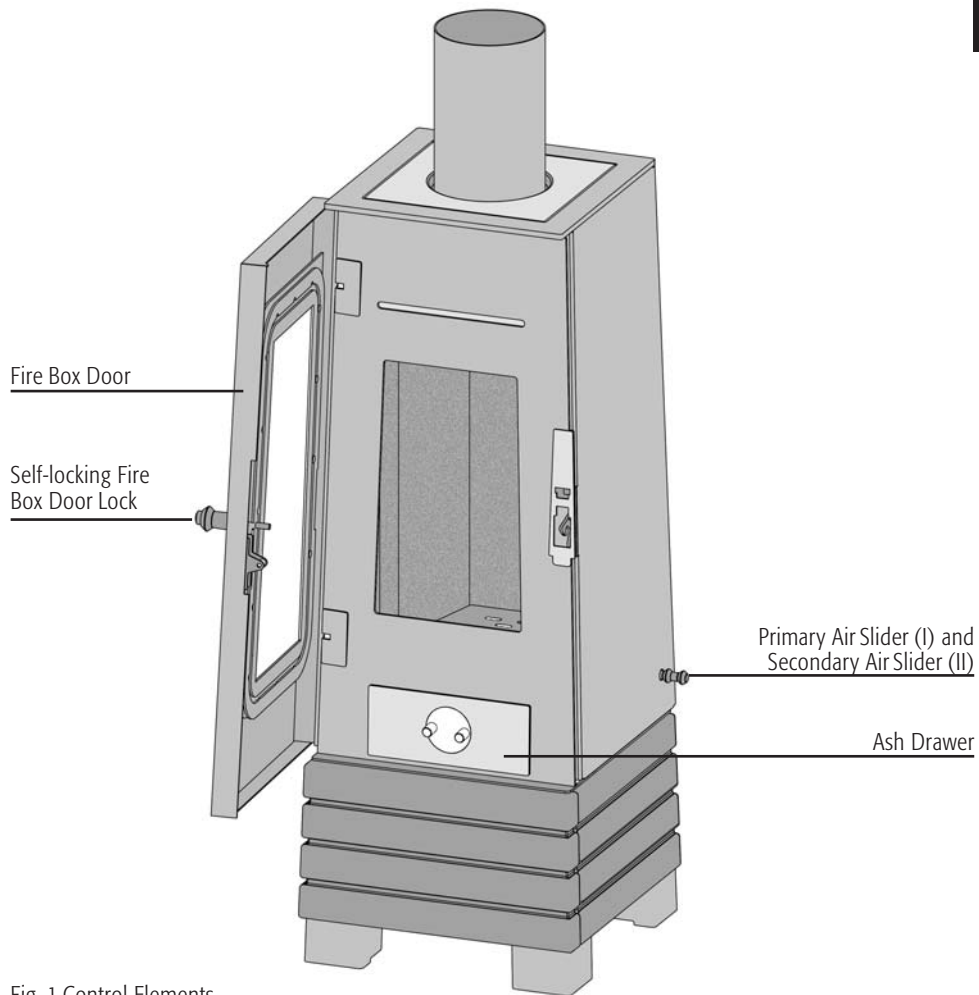

Fig. 1 Control Elements

Dear HASE Customer,

In purchasing a Hase stove, you have decided on a high-quality product. Traditional craftsmanship, classic design and state-of-the-art combustion technology guarantee many years of enjoyment with your AKABA stove.

The stove body of your HASE stove is comprised of strong modern welded steel plates. The heat-resisting slabs in the fire box and the HASE Air System ensure optimal combustion. It goes without saying that we place great value in using materials of superior quality and take the utmost care in the manufacturing of our stoves. All the control elements are very conveniently located and easy to use.

Please read carefully through these operating instructions. They provide important instructions and offer useful tips for enjoying cosy hours around the fire.

We hope you will enjoy your new HASE Feuermöbel.

**Yours sincerely,
Hase Kaminofenbau GmbH**

	Page
1. Installation Conditions and Relevant Building Regulations	65
2. Safety and Safety Distances	65
3. Installation	66
4. The Chimney	66
5. Construction Type in Compliance with DIN 18891	66
6. Flue Pipe Connection	66
7. Combustion Air Connection	67
8. Fuel Load Sizes and Thermal Output	67

	Page
9. Regulating the Combustion Air	67
9.1 Primary Air	67
9.2 Secondary Air	67
10. Initial Operation	68
11. Lighting the Fire	69
12. Adding Fuel (Wood)	69
13. Heating at Low Thermal Output	70
13.1 Partial Load Operation	70
14. Emptying the Ash Drawer	71
15. The Combustion Process	71
15.1 Drying Phase	71
15.2 Degasification Phase	71
15.3 Burn-off Phase	72
15.4 Expansion Noises	72
16. The Right Fuel	72
17. The Chemistry of Wood	73
18. Contribution to Environmental Protection	73
19. Evaluating the Combustion Quality	73
20. Wood Moisture Content and Calorific Value	74
21. Storing and Drying Wood	74
22. Assessing Wood Moisture Content	74
23. Cleaning and Maintenance	75
23.1 Steel Cladding	75
23.2 Flue Gas Paths	75
23.3 Ceramic Glass Panels and Windows	76
23.4 Fire Box Lining	76
23.5 Sealing Strips	76
23.6 Fire Box Locking Mechanism and Hinges	76
Useful tips	77
Technical Data	78

The AKABA is suitable for **direct vent operation**. It is equipped with a self-locking fire box door lock.

1. Installation Conditions and Relevant Building Regulations

Before installing your AKABA stove, we recommend talking to your local planning officer. He or she will advise you on the relevant building regulations, grant you the permit and conduct the approval inspection.

The pertinent valid technical regulations and standards as well as the country-specific requirements, such as the respective state building code, German Combustion Ordinance, DIN 18896 (Draft) and/or other regional regulations have to be complied with.

2. Safety and Safety Distances

At the front and sides of the stove, no flammable, combustible or heat-sensitive materials (e.g. furniture, wood or plastic panelling, curtains, etc.) are to be located within a distance of 80 cm in the heat radiating area of the fire box window. In regards to flammable materials beyond the heat radiating area, a safety distance of 20 cm at the sides of and behind the stove has to be adhered to (see Fig. 3).

Children should never be left unattended near the burning stove.

In accordance with the German Combustion Ordinance Draft, flammable flooring materials (wood, laminate, carpeting,) must be protected with a floor plate made of non-combustible material (tiles, safety glass, slate or sheet steel).

When using a floor plate, the safety distances stipulated by DIN 18891 apply.

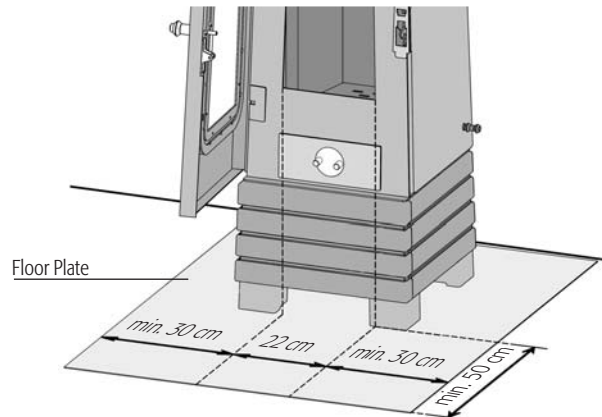

Fig. 2
Distances to Heat-sensitive and Combustible Materials

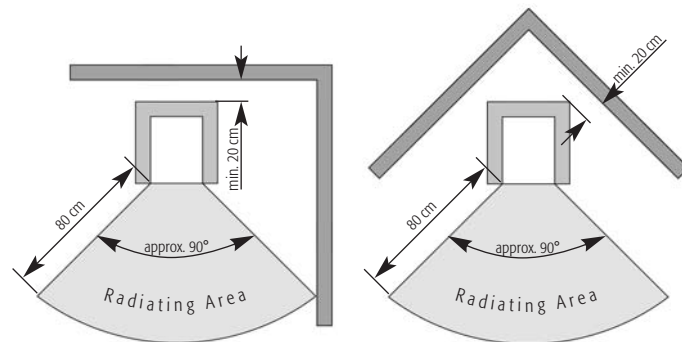

Fig. 3
Layout for Wall Location

Layout for Corner Location

3. Installation

The door of the AKABA is self-locking. To ensure that the self-locking mechanism functions perfectly, use the spirit level to precisely align the AKABA in a horizontal position. The stove can be aligned by means of four levelling feet (see Assembly and Maintenance Instructions).

Please make sure that there is sufficient ventilation in the room where the AKABA will be installed.

For rooms with a cubic volume of more than 50 m³, an hourly air exchange ratio of 1.5 is required. With smaller rooms, the air change rate needs to be higher. The negative pressure in the room where the stove is installed is not permitted to exceed the value of 8 Pascal (the ventilation system designer specifies the air pressure in Pascal units). We recommend setting the ventilation system to a maximum negative pressure of 4 Pascal. To ensure that no air is drained from the room, we recommend operating exhaust hoods in recirculation air mode or using a window contact switch to lock exhaust hoods that guide air to the outside.

4. The Chimney

The AKABA needs its own separate chimney.

The draught capability of your stove can be impaired by a chimney cross section that is too large or too small and/or an effective chimney height of less than 4.50 m. The "effective chimney height" is the distance between the flue gas intake in the chimney and the top of the chimney pot. After a soot fire in the chimney, the impermeability (air-tightness) of the flue gas paths has to be checked.

We recommend connection to a multi-leaf chimney with a cross-section having a maximum diameter of 160 mm and a minimum "effective chimney height" of 4.5 m.

If these specifications cannot be met, we advise you to check the suitability of the chimney by means of a chimney calculation.

5. Construction Type in Compliance with DIN 18891

The AKABA may only be operated when the fire box door is closed (Construction Type 1).

In direct vent mode, the AKABA has to be connected to its **own** separate chimney (deviating from DIN 18891 - Construction Types of Stoves)

6. Flue Pipe Connection

The AKABA has to be connected to the chimney with a flue pipe having an inside diameter of 150 or 120 mm. The flue pipe has to be sealed at the flue pipe connection piece with Hase Sealing Paste.

The flue pipe connection to the chimney has to be gas proof and sealed with a suitable sealing cord and heat-resistant silicone (see Fig. 7). The flue pipe cannot project into the cross-section of the chimney, as that can impair flue venting.

We recommend using a one-piece flue pipe. The total length of the connecting pipe between the stove and the chimney should not exceed 1.50 m.

7. Combustion Air Connection

The combustion air in the fire box is solely supplied by a customer-provided supply air pipe and the Hase Air System pipe connections. The connecting piece for the Hase Air system is located on the back side of the stove. The sealed pipe connections are either routed directly to the outside or connected to a suitable air/flue gas system (AFS). Another option is to provide the supply air from a room with its own independent outside air supply (e.g. cellar or basement) (see Figs. 7 - 9).

For the customer-provided installation of the air inlet, plain pipes (steel pipes in compliance with 24145, drain pipes in accordance with DIN 19534 and EN 1451B) with a minimum diameter of 100 mm, a maximum of two bends and a permissible total length of 5 meters should be used. Verification by calculation is required for longer piping and more than two bends.

The air supply pipe has to be equipped with an inspection opening for inspecting and cleaning purposes. The entire air supply pipe has to be airtight.

We advise discussing this with your local planning officer.

At the air inlet opening, we recommend installing an animal protection screen with a mesh size of 10 mm.

8. Fuel Load Sizes and Thermal Output

The thermal output depends on the amount of fuel you burn in the stove (fuel load size). When adding more fuel (e.g. wood), the maximum fuel load size is 1 kg. Exceeding the maximum fuel load size leads to a danger of overheating, possibly resulting in damage to the stove and risk of a stove fire.

A thermal output of 4 kW can be attained by burning wood logs weighing approx. 0.8 kg and approx. 20 cm in length for approx. 40 min.

To attain thermal output of 2.5 kW, burn wood logs weighing approx. 0.3 kg and approx. 20 cm in length for approx. 25 min.

9. Regulating the Combustion Air

When lighting the fire and adding fuel, the combustion air is regulated with the primary air and secondary slider.

9.1 Primary Air

The primary air is guided through the grate and into the fire box from below, thus more quickly achieving the required fire box temperature during the warming up phase.

9.2 Secondary Air

The secondary air is guided into the fire box via air ducts from the top. It supplies the fire box with the volume of preheated oxygen necessary to completely burn off the wood gas and, if used correctly, ensures that the fire box window remains free of soot.

For regulating the secondary air, the following general rule applies: a small fire requires little secondary air; a large fire requires ample secondary air.

If the secondary air valve is closed too tightly, there is the risk of the flue gases not completely burning (smouldering fire) and/or soot build-up on the fire box window or that the amassed wood gases will burn explosively (over firing/deflagration).

Please note: Burning wood when the primary air slider is opened too wide poses the risk of overheating the stove (forge fire effect). During operation, the secondary air slider should never be completely closed. The fire box door and ash compartment must always be tightly shut.

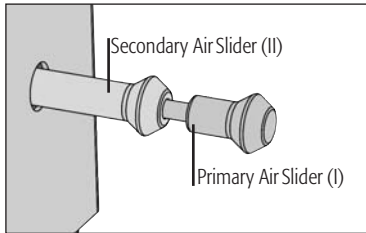

Fig. 4
The control elements are located on the lower right side of the AKABA.

10. Initial Operation

Please note that a slight odour may be emitted during the first two to three initial burning processes.

During the first burning process, please ensure that the room is sufficiently ventilated.

During shipment to you, condensation moisture can accumulate in the stove's interior, which may possibly lead to the appearance of condensation or water on the stove or flue pipes.

Please dry off these damp areas immediately.

The surface of your stove was degreased in a sandblasting machine before being lacquered. Despite careful and thorough inspection, there may still be some blasting material (small steel pellets) in the stove body, which can fall out when your stove is being installed.

To prevent any damage, please immediately vacuum up these little steel pellets with a vacuum cleaner.

11. Lighting the Fire

The firing up phase should be as short as possible, since higher emission value rates can occur during this phase. The slider settings described in Table 1 are recommendations that were determined under testing conditions, in compliance with the relevant standard.

Depending on the weather conditions and the draught capability of your chimney, accordingly adjust the slider positions for your AKABA to the local conditions.

You can prevent water condensation from building up on the fire box window by cracking open the fire box door for one or two minutes during the warming up process. Make sure that the fire box door is locked again after this time.

Never use spirits, petrol or other flammable fluids to light the stove.

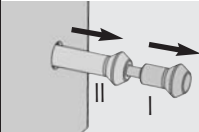
Lighting the Fire	
Procedure	Position of Control Elements
Completely open primary and secondary air.	Pull primary and secondary air sliders all the way out. 
Pile up any remaining ash and unburned Charcoal into the centre of the combustion chamber. Place ignition material into the middle of the fire box; stack approx. 0.5 kg of dry wood chips on top. Light the ignition material at several places.	Open fire box door.
	Close fire box door.
As soon as the wood chips begin to completely burn, place two wood logs (approx. 0.5 kg total weight) with the small side facing forward.	

Tab. 1

12. Adding Fuel (Wood)

More fuel (wood) should be added to the fire during the burning off phase, when the flames from the previous burning off phase have just gone out.

When the fire box door is opened, air flows into the stove, which in turn causes an increase in the amount of flue gas in the chimney.

When stoking the fire, open the fire box door very slowly to minimise the emergence of flue gases and prevent ashes from swirling up in the fire box.

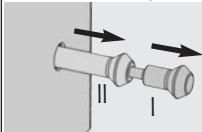
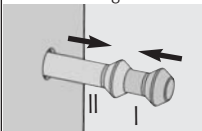
Adding Fuel (Wood)	
Procedure	Position of Control Elements
Completely open primary and secondary air.	Pull primary and secondary air sliders all the way out. 
Add a log weighing approx. 0.8 kg with the small side facing forward. Place logs with the bark facing upwards or outwards. Only add a single layer of fuel (wood).	Open fire box door.
After igniting the log, close the primary air and completely open the secondary air.	Push in primary air slider as far as it will go. Pull out secondary air slider as far as it will go. 
	Close fire box door.

Tab. 2

13. Heating at Low Thermal Output

The thermal output of your AKABA stove is primarily affected by the quantity of fuel used.

Do not attempt to slow down the combustion by reducing the air supply. When heating with wood, this can result in an incomplete burning process and pose the risk of explosive-like combustion of the accumulated wood gases (deflagration).

Heating at Low Thermal Output	
Procedure	Position of Control Elements
Close primary air.	Push in primary air slider (I) as far as the secondary air slider allows.
Completely open secondary air.	Pull out secondary air slider as far as it will go.
Add a log (approx. 0.3 kg) with the small side facing forward.	

Tab. 3

13.1 Partial Load Operation

Burning off a fuel load weighing 0.8 kg for approx. 45 minutes will yield a thermal output of 3.3 kW.

Partial Load Operation	
Procedure	Position of Control Elements
Close primary air.	Push in primary air slider (I) as far as the secondary air slider allows.
Close secondary air.	Push in secondary air slider as far as it will go.
Add a log (approx. 0.3 kg) with the small side facing forward.	

Tab. 3.1

14. Emptying the Ash Drawer

For safety's sake, please make sure that you only dispose of ashes once they are cold. While the ash collects, the lid is located under the ash drawer.

Unlock the ash drawer. Remove both the ash drawer and the lid located underneath it. Slide the lid onto the ash drawer so that it is closed; this prevents ashes from flying around, which in turn means your home stays clean. To place the ash drawer back into the stove, proceed in the reverse order.

Piled up ashes can prevent or even block the primary air supply to the stove. Ensure that the ventilation path for the primary air between the ash drawer and the bottom of the ash compartment remains clear.

15. The Combustion Process

A piece of wood burns in three phases. In a wood fire, however, these processes take place both consecutively and simultaneously

15.1 Drying Phase

The moisture still remaining in the air-dried wood (approx. 15 - 20%) is evaporated. This takes place at temperatures of approx. 100°C. For the evaporation to occur, the wood must be supplied with heat during the warming up phase; this is achieved by using small wood logs.

15.2 Degasification Phase

At temperatures of between 100°C and 150°C, the contents of the wood start (slowly at first) to disintegrate and gasify and the wood begins its thermal decomposition. At temperatures above 150°C, the gas development increases strongly. The proportion of volatile components

makes up around 80% of the wood substance.

At a temperature of about 225°C (ignition temperature), the actual combustion begins with the ignition of the resulting gases and the release of heat. There must be an adequate supply of oxygen available for this purpose. The peak of the combustion process is reached at approx. 300°C. The reaction process is now so rapid that the largest amount of heat is released at this point; flames can reach temperatures of up to 1100°C.

15.3 Burn-off Phase

Glowing charcoal embers remain after the volatile components have been burned off. These burn slowly, almost without flames, at a temperature of approx. 800°C.

Crucial to a clean and efficient combustion process is a complete (as possible) chemical

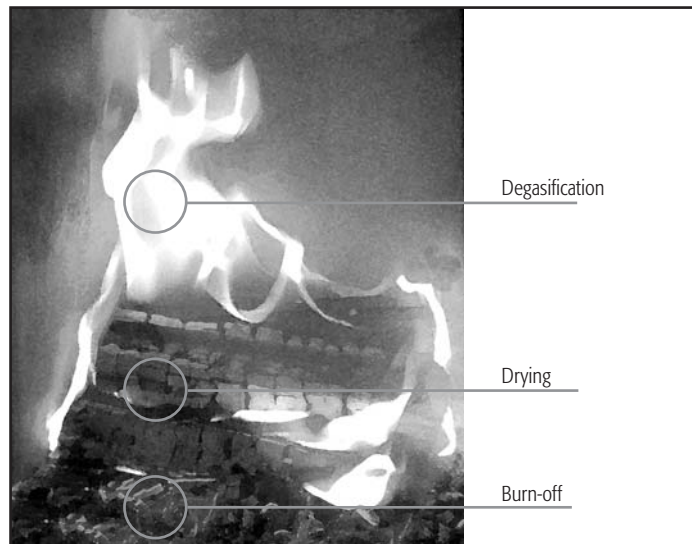

72 Fig. 5 The Combustion Process

reaction of the wood gases with the oxygen in the combustion air. With your Hase stove, the combustion air is pre-heated and guided into the fire box via wide air inlet openings, enabling a good and thorough mixing of the gases with the air. An important variable in any combustion phase is the amount of combustion air. Not enough air leads to an oxygen deficiency and incomplete combustion, while too much air reduces the fire box temperature and thus the efficiency. Incomplete combustion can generate air pollutants such as dust, carbon monoxide and hydrocarbons.

15.4 Expansion Noises

Steel expands upon heating and contracts as it cools, which can cause your stove to emit audible expansion sounds. However, the design and construction of your stove takes this into account and prevents this physical process from damaging the stove.

16. The Right Fuel

Pursuant to the First Ordinance on the Implementation of the German Federal Emission Control Act, only fuels which generate low quantities of smoke may be burned in stoves. For the AKABA, these are natural, untreated wood logs, including the adherent bark.

Highly resinous coniferous wood (e.g. spruce, pine, fir) tends to emit flying sparks and leaves behind a fine layer of flue ash that can swirl up when the fire box door is opened.

For the most attractive stove fire, use beech wood logs. If other types of wood are used, such as oak, birch, pine or larch, we recommend adding beech wood for picturesque dancing flames. Brushwood and small pieces of wood are good kindling materials.

The burning of e.g.:

- damp or moist wood (residual moisture content over 20%),
- varnished or plastic-coated wood,
- wood treated with wood preservatives,
- household waste, or
- paper briquettes (pollutants: cadmium, lead, zinc)

is not permitted.

Combustion of the materials listed above not only gives off unpleasant odours, but also generates emissions that damage the environment and are harmful to health.

17. The Chemistry of Wood

Wood predominantly consists of the elements carbon, hydrogen and oxygen. It contains virtually no environmentally hazardous substances such as sulphur, chloride and heavy metals. As a result, complete wood combustion produces mainly carbon dioxide and water vapour as the primary gaseous products as well as a small quantity of wood ash as the solid combustion residue. On the other hand, incomplete combustion can generate a number of pollutant substances, such as carbon monoxide (toxic), acetic acid, phenols, methanol (toxic), formaldehyde, soot and tar.

18. Contribution to Environmental Protection

Whether your AKABA burns in an environmentally-friendly or environmentally hazardous manner depends to a large extent on how you operate it and the type of fuel you use (see "The Right Fuel").

Use only dry wood; hardwoods such as birch and beech are most suitable

Only use small pieces of wood to light the fire. They burn faster than large logs and thus the temperature required for complete combustion is reached more quickly.

For continual heating, adding smaller quantities of wood more frequently is more efficient and more ecological.

19. Evaluating the Combustion Quality

The following characteristics can facilitate easy evaluation of the combustion quality:

- Colour and composition of the ash

If the combustion process is efficient, the result is a fine white ash. Dark colouration indicates that the ash contains charcoal residue; in this case, the burn-off phase was incomplete.

- The colour of the flue gases emitted at the chimney pot

In this respect, the following applies: the more invisible the flue gases exiting the chimney, the better the combustion quality.

During the transitional seasons (spring/autumn), outdoor temperatures above 16°C can impair the chimney draught. If a draught cannot be created at these temperatures by rapidly burning paper or thin wood shavings (quick fire), you should refrain from lighting the stove.

20. Wood Moisture Content and Calorific Value

Rule of thumb: the more damp the wood, the lower the calorific value

The calorific value of the wood depends largely on the wood moisture content. The more moisture the wood contains, the more energy expended to evaporate it during the combustion phase; this energy is then lost. Thus, the more damp the wood, the lower its calorific value. An example: freshly cut wood has a moisture content of approx. 50% and a calorific value of around 2.3 kWh/kg; in contrast, wood which has been efficiently air-dried has a moisture content of approx. 15% and a calorific value of around 4.3 kWh/kg. Accordingly, if you burn very moist wood, you will have about half the thermal output with the same quantity of wood. Furthermore, burning moist wood results in substantial soot build-up on the fire box window. Moreover, when moist wood is burned, the resulting water vapour can condense in the flue pipe or chimney. This can lead to a build up of shiny soot on the chimney or chimney creosote. In addition, if the wood has a high moisture content, the combustion temperature decreases, which prevents complete combustion of all the wood components and causes considerable environmental pollution.

21. Storing and Drying Wood

Wood needs time to dry. If stored properly, it will air-dry in approx. 2 to 3 years.

Saw, split and store the wood ready for use; this ensures rapid drying because smaller pieces of wood dry better than larger, uncut logs.

Stack and store your wood logs in a ventilated and as sunny as possible location, ideally facing south, and ensure that they are protected from rain.

Leave a hand's width between the individual piles of wood so that air can flow between them and carry away any escaping moisture.

Do not cover your stacks of wood with plastic sheeting or tarpaulins; otherwise the moisture cannot escape.

Do not stack fresh wood in a cellar or basement, since it will rot rather than dry due to the lack of airflow.

Only store already dried wood in dry and well-ventilated cellar or basement rooms.

22. Assessing Wood Moisture Content

You can assess whether your firewood is sufficiently air-dried (residual moisture content of less than 20%) or whether it must be stored longer. Wood is considered air-dried when the moisture content of the wood is in balance with the ambient air, i.e. it no longer dissipates moisture to the air and no longer absorbs moisture from the air. A constant weight indicates that the log is in an air-dried state.

Proceed as follows:

Take a log from various sections of your wood pile.
 Mark those logs so that they can be unambiguously identified.
 Weigh the logs on a kitchen scale and note down their weights.
 Dry the logs (e.g. near the stove in compliance with the safety distances to flammable/combustible materials or in the oven at 100°C).
 Place the logs back in the wood pile in their original location.
 Weigh the logs again one or two days later.

The drying process will disrupt the moisture balance. Once dried, the logs will therefore attempt to reproduce the balance by absorbing moisture from the air. If the logs have the same weight as when they were first weighed, they have absorbed the same quantity of water that they lost through the drying process. This means that the moisture had already balanced out before the wood was weighed for the first time. On the contrary, if the logs weigh less, they contained more water before the first weighing. In this case, your firewood has to be dried for a longer period of time.

23. Cleaning and Maintenance

23.1 Steel Cladding

Hase stoves are coated with a heat-resistant open porous lacquer that provides only limited corrosion protection; accordingly, a rust film may develop in some cases.

Do not use any detergents containing acid (e.g. citrus or vinegar cleaners) to clean the steel parts. The steel parts can be sufficiently cleaned by wiping them down with a slightly moistened cloth.

Avoid using excessive water to clean the floor/floor plate areas.

Spilt water from kettles, boilers or water tanks should be immediately mopped up.

Do not install the AKABA in "damp rooms", e.g. conservatories or enclosed porches. Avoid temporary storage in unheated building shells or garages.

Treat areas covered in a rust film with the original Hase Stove Lacquer Spray. Be sure and follow the instructions on the spray can. Your authorised HASE specialist dealer stocks the stove lacquer spray and can give you tips on using it.

23.2 Flue Gas Paths

The stove and flue pipes should be inspected for sediment and deposits at the end of each year's heating period (even more often if required, e.g. after the chimney has been cleaned), and cleaned if necessary. To clean the flue gas paths, lift out the heat-resisting slab in the fire box. Any soot or dust sediment/deposits can be brushed off and vacuumed away. Then re-insert the heat-resisting slab.

For more information, please refer to the Assembly and Maintenance Instructions.

23.3 Ceramic Glass Panels and Windows

When the stove is properly operated, the secondary air simultaneously forms an air curtain at the pane, which prevents sooting of the glass.

If ash particles get on the ceramic glass panels, we recommend a tried and true environmentally-friendly cleaning method:

Take some balled-up paper towelling or newspaper, moisten it, dip it into the cold wood ash, rub the panel with it and then wipe the glass with a clean, dry ball of paper.

23.4 Fire Box Lining

The heat-resisting slabs in your stove's fire box are made of Vermiculite. Vermiculite is a fire-resistant mineralogical granulate material with excellent insulating properties. The density of the slabs is a result of the optimal balance between mechanical stability and insulation properties.

The relatively soft surface is subject to natural wear and tear, depending on use. The heat-resisting slabs have to be replaced if parts break off and the back wall of the fire box, located behind the slabs, becomes visible. Tears or cracks in the heat-resisting slabs do not impair the functioning of your stove.

To reduce the damage to the heat-resisting slabs, place logs carefully in the fire box and do not let them fall against the walls of the fire box.

23.5 Sealing Strips

The sealing strips for the fire box door and ash box are made of highly heat-resistant, asbestos-free fibreglass. The sealing strips are wearing parts and thus have to be replaced in line with the frequency of use.

23.6 Fire Box Locking Mechanism and Hinges

To keep the fire box door moving smoothly, the locking mechanism and hinges should be lubricated from time to time.

For more information, please refer to the Assembly and Maintenance Instructions.

Possible Problem	Possible Cause
The wood does not light or lights only slowly.	<ul style="list-style-type: none"> - The wood is too thick. / The wood is too damp. - The air supply is insufficient.
The wood burns without a bright, yellow flame, smoulders or even goes out.	<ul style="list-style-type: none"> - The wood is too damp. - The air supply is insufficient. - The outside temperature is too high.
Too much soot is generated; the heat-resisting slabs do not stay clean and free of soot during operation.	<ul style="list-style-type: none"> - The wood is too damp. - The air supply is insufficient. - The quantity of wood is too small and thus the combustion chamber remains too cold.
The fire box window becomes sooty.	<ul style="list-style-type: none"> - The wood is too damp. - The secondary air supply is insufficient. - The fire box door is not tightly sealed. - The chimney draught is too weak.
The wood burns off too quickly.	<ul style="list-style-type: none"> - The chimney draught is too strong. - The wood logs are too small. - The control elements are incorrectly positioned or set.
Smoke escapes into the room while the stove is in operation.	<ul style="list-style-type: none"> - The air supply is insufficient. - The chimney cross section is too narrow. - The flue gas ducts in the stove pipe or chimney are extremely sooty. - Wind is blowing down on the chimney. - Fans (bathroom, kitchen) are creating negative pressure in the living room and drawing smoke from the stove.
The chimney becomes wet and coated with creosote, condensate leaks out of the stove pipe.	<ul style="list-style-type: none"> - The wood is too damp. - The flue gases are too cold. / The chimney is too cold. - The chimney cross section is too wide.
Smoke escapes when the fire box door is opened.	<ul style="list-style-type: none"> - The chimney draught is too weak. / The chimney cross section is too wide or too narrow. - The fire is still burning too strongly. - The fire box door was opened too rapidly. - Fans (bathroom, kitchen) are creating negative pressure in the living room and drawing smoke from the stove.

Tab. 4 Your authorised Hase dealer or local planning officer will be glad to answer any questions you might have.

TECHNICAL DATA

The **AKABA direct vent stove**, certified in compliance with **DIN 18891-1, DIN 18897-1 (Entwurf) und Art. 15 a B-VG (Austria)**, can only be operated when the fire box is closed; needs its own separate chimney.

Conforms with the DIBT (Deutschen Institut für Bautechnik/German Institute for Building Technology) approval criteria for direct vent fire-places for solid fuels.

DIBT approval number: applied for Typ FC_{41x} und FC_{51x}
VKF No.: applied for.

Combustion Values:

The following data applies to the chimney characteristics in accordance with DIN 4705:

Nominal Thermal Output	4	kW
Min/Max Thermal Output Range	2,1 - 4,2	kW
Fuel Heat Output	5,1	kW
Waste Gas Mass Flow Rate	4	g/s
Waste Gas Outlet Temp.	350	°C
Min. Supply Pressure at Nominal Thermal Output	10	Pa

Depending on the insulation of the building, the nominal thermal output of 6 kW (in accordance with DIN 18893) indicated on 25 bis 62 m³

Dimensions:	Height	Width	Depth
Stove:	111,3 cm	41 cm	41 cm
Fire box:	43 cm	20 cm	26 cm
Weight:		118 kg	
Fire Box Opening:		775 cm ²	
Flue pipe diameter:		150 mm	
Pipe diameter of Hase ventilation system*:		100 mm	

*For separate air supply in the case of low-energy houses & mechanical room ventilation systems

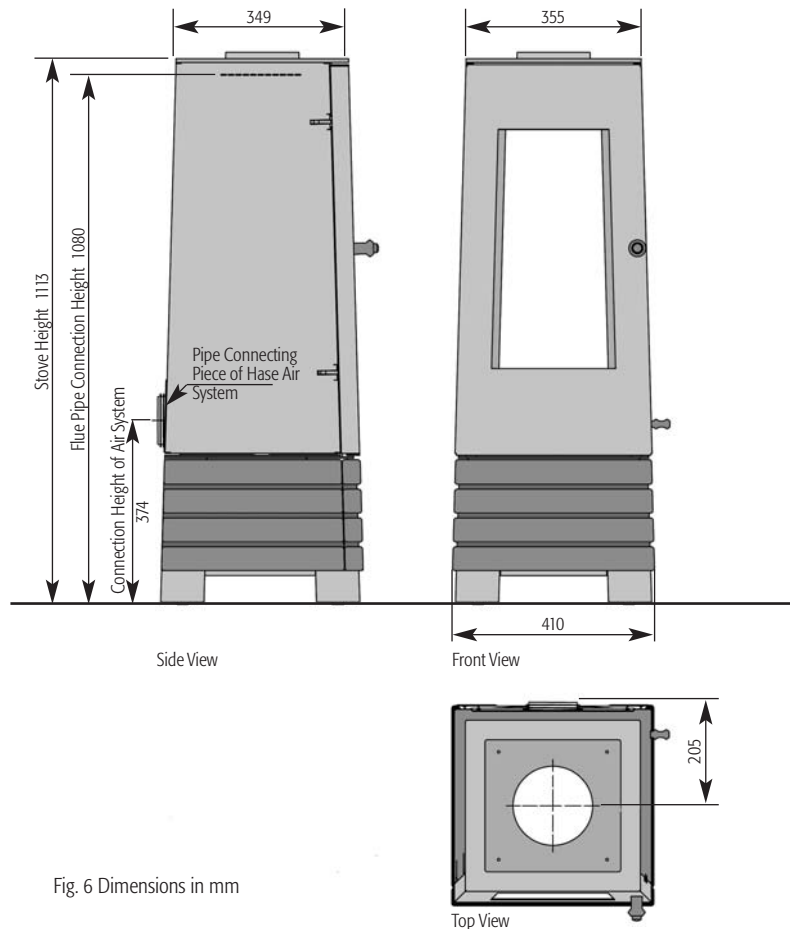

Fig. 6 Dimensions in mm

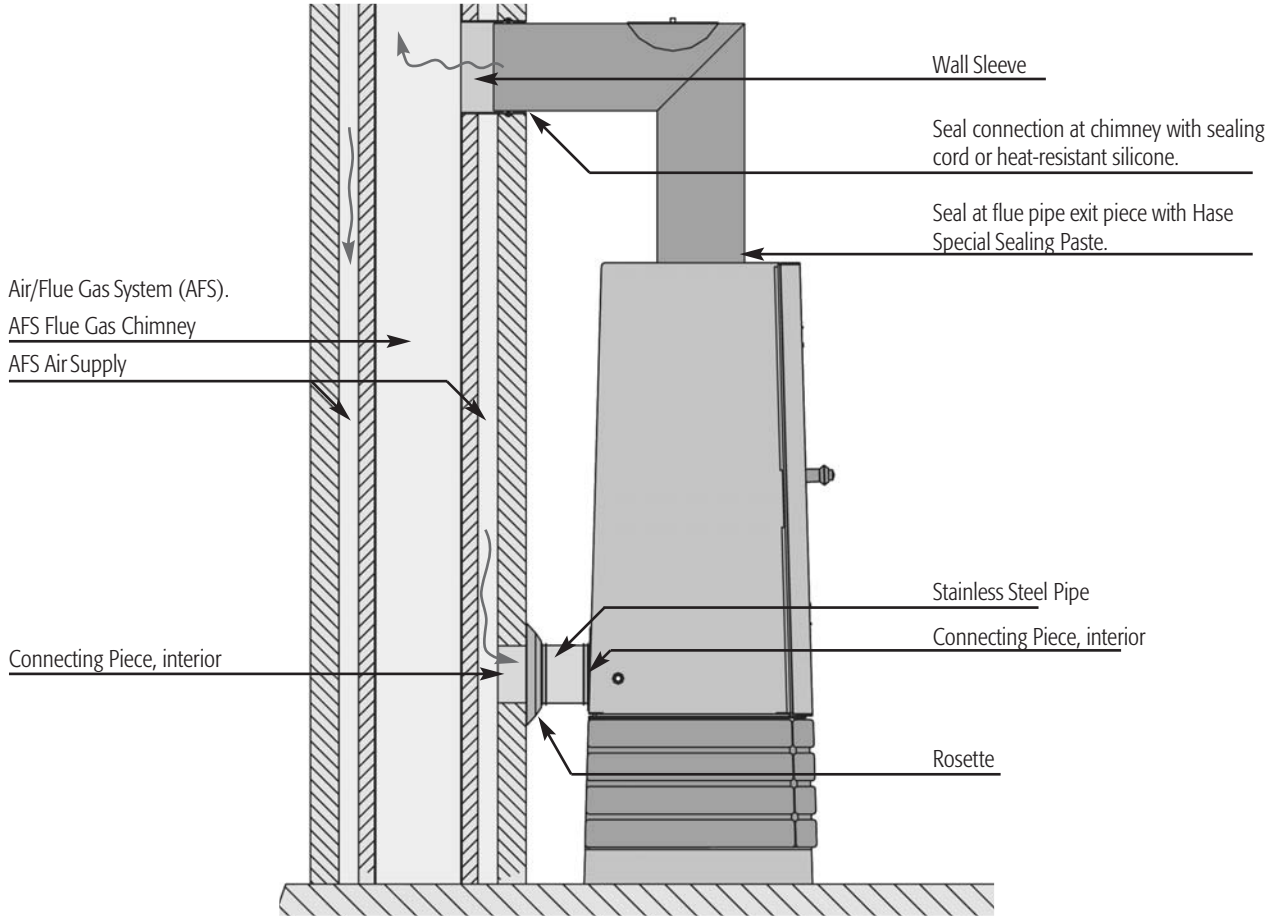

Fig. 7 Connection to an Air/Flue Gas System (AFS)

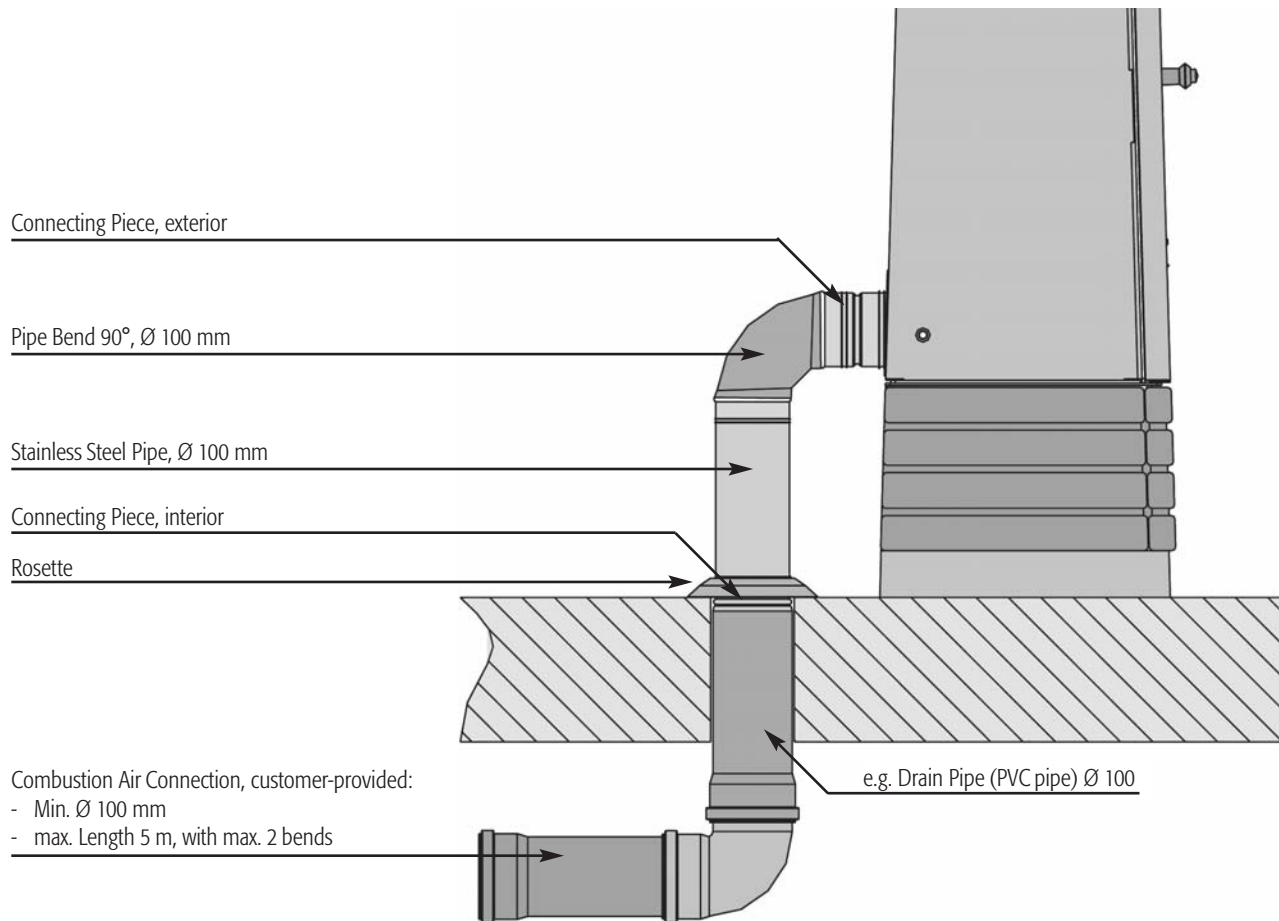

Fig. 8 Connection to an Air Supply Pipe.

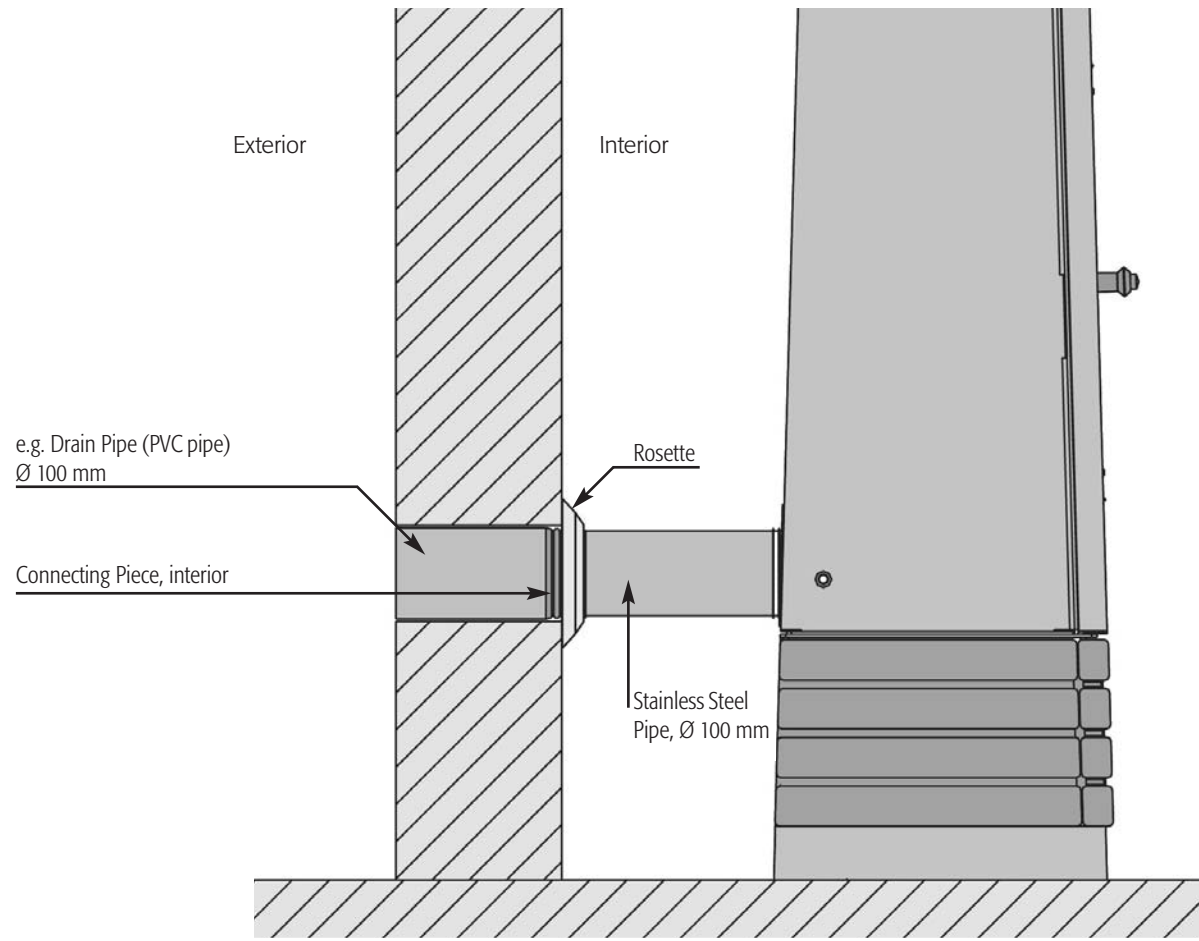

Fig. 9 Connection to an Air Supply Pipe

Dear Customer

Congratulations on purchasing a Hase stove. The materials and quality of this product are continually monitored and tested. We are convinced that it is of the highest quality and therefore provide a warranty for all Hase stoves for a period of **5 years**, beginning with the date of delivery. This warranty covers:

- fault-free function
- perfect material
- fault-free design.

If you have reason for complaint with regard to any of these points, please contact your local Hase dealer. He will act as your contract partner and is responsible for meeting the conditions of the warranty. Your dealer will check immediately the validity of any warranty claim and will report it to Hase Kaminofenbau GmbH for you. (If you move, the Hase dealer in your region automatically becomes your contract partner; the address can be obtained from the manufacturer or from the general representative).

A warranty claim can only be made if the stove is used in accordance with our operating instructions. Misuse, incorrect use or the use of force or violence render the warranty invalid. For this reason, the warranty excludes the following:

- Damage caused by incorrect mounting of the stove
- Damage caused by fuels which are not recommended in the operating instructions
- Damage caused by natural wear (e.g. on thermal plates, ceramic glass, sealing strips, closing rods, flame guiding plate)
- Damage caused by attempted repairs by unauthorised persons.

Repairs carried out under warranty in no way cause the warranty period to be extended and a new warranty period is not provided for parts which are fitted or repaired at a later stage.

If a stove is returned to the factory, the costs for transport, disassembly, assembly and repairs will only be covered in the event of a valid warranty claim.

This warranty is only valid when presented with the original invoice and completed warranty card.

We hope that you enjoy using your new Hase stove.

PLEASE COMPLETE AND RETURN

Please fill in the postcard and return within 14 days after purchase of your fire to **secure your warranty**.

Designation of Hase model: _____

Delivery date: _____

Name and location of dealer: _____

Warranty number.: _____

The warranty number is located on the back of the stove and on the sticker attached to the fire chamber window.

To enable us to improve constantly the quality of our products and service, please answer the following questions. Thank you.

How did you first come into contact with Hase?

- friend or relative
- trade fair
- specialized outlet
- Internet
- newspaper / magazine (which?)

What made you choose a Hase model?

- quality of the finished product
- design
- technological features
- environmentally friendly
- combustion
- other reasons (which?)



Bitte kleben Sie hier Ihre Garantie-Nr. auf
(siehe Ofenrückseite bzw. Aufkleber Feuerraumscheibe).

Veuillez coller votre N° de garantie à cet endroit
(voir la face arrière du poêle ou l'autocollant sur la vitre du foyer).

Applicare qui il vostro numero di garanzia
(vedi parte posteriore della stufa, ossia l'etichetta della lastra del focolare).

Please affix your warranty number here
(located on the back of the stove and on the sticker attached to the fire chamber window).

Plakt u hier s.v.p. uw garantienummer in
(zie de achterzijde van de kachel en de sticker op de kachelruit).

hase 

Hase-Kaminofenbau GmbH
Niederkircher Str. 14 · D-54294 Trier
Tel.: (06 51) 82 69-0
Fax: (06 51) 82 69 118
hase@kaminofen.de
<http://www.kaminofen.de>

Sender:

Surname, first name:

Street:

Town / country:

Please affix stamp
if available.

Reply card

Please forward to your national agent
- or if there is none, to Hase, Trier